

AlphoD

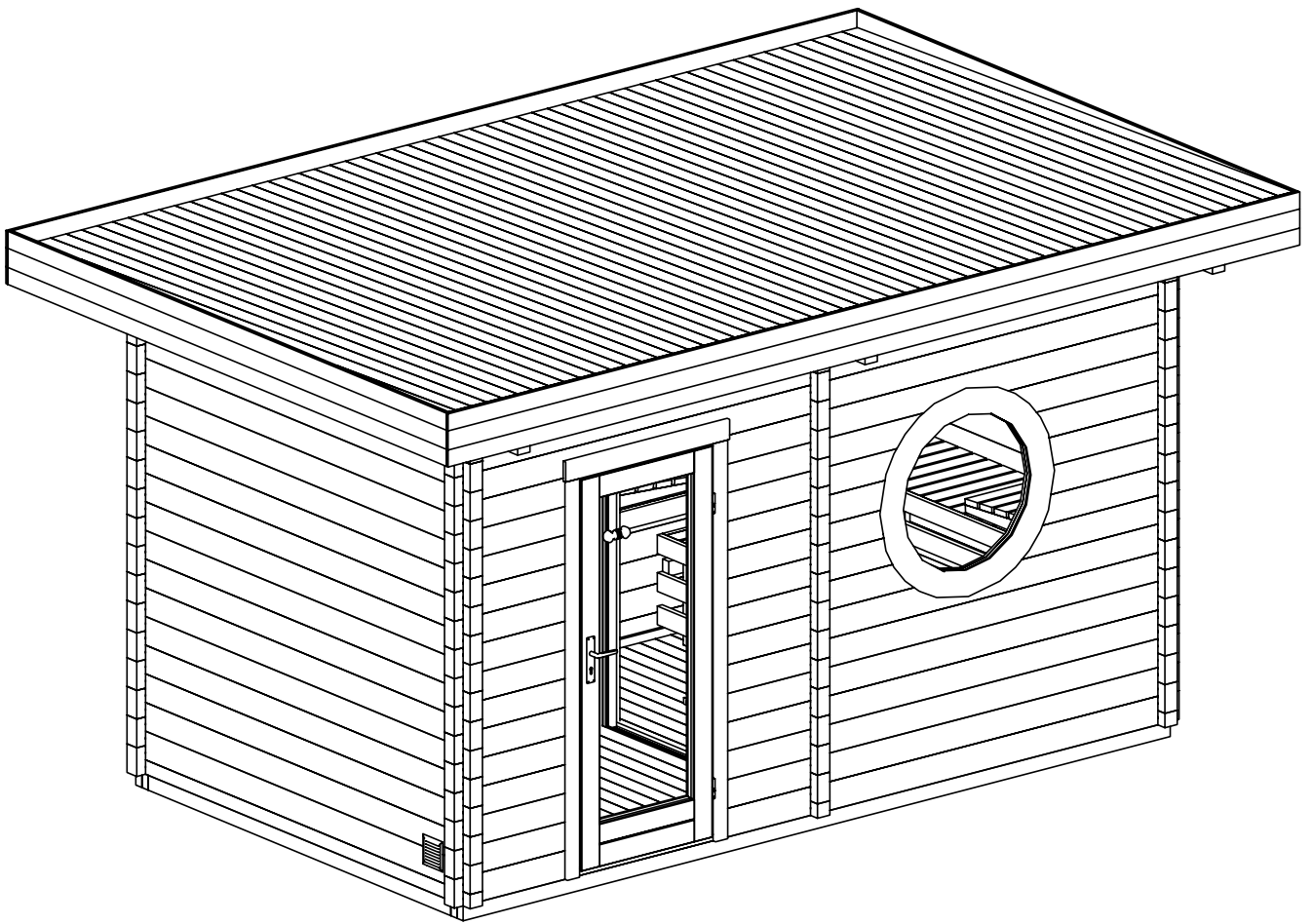

Sauna Cubus 70 C

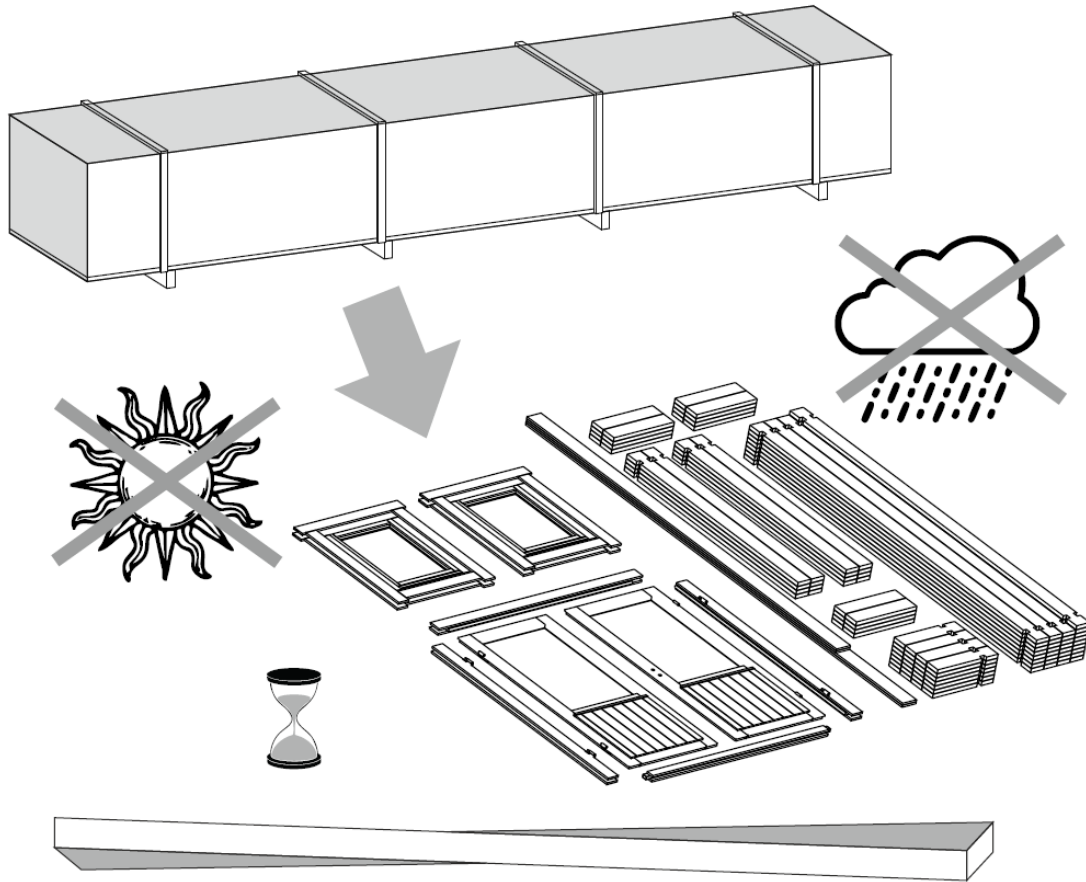

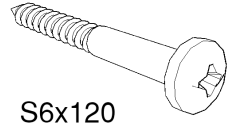
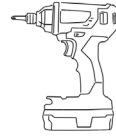
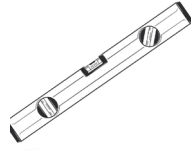
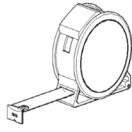
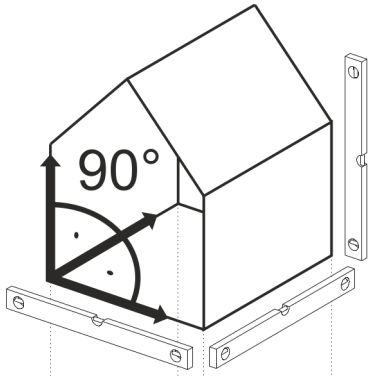

S6x120

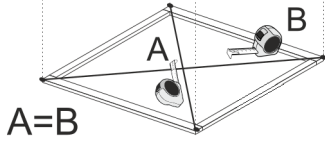

A=B

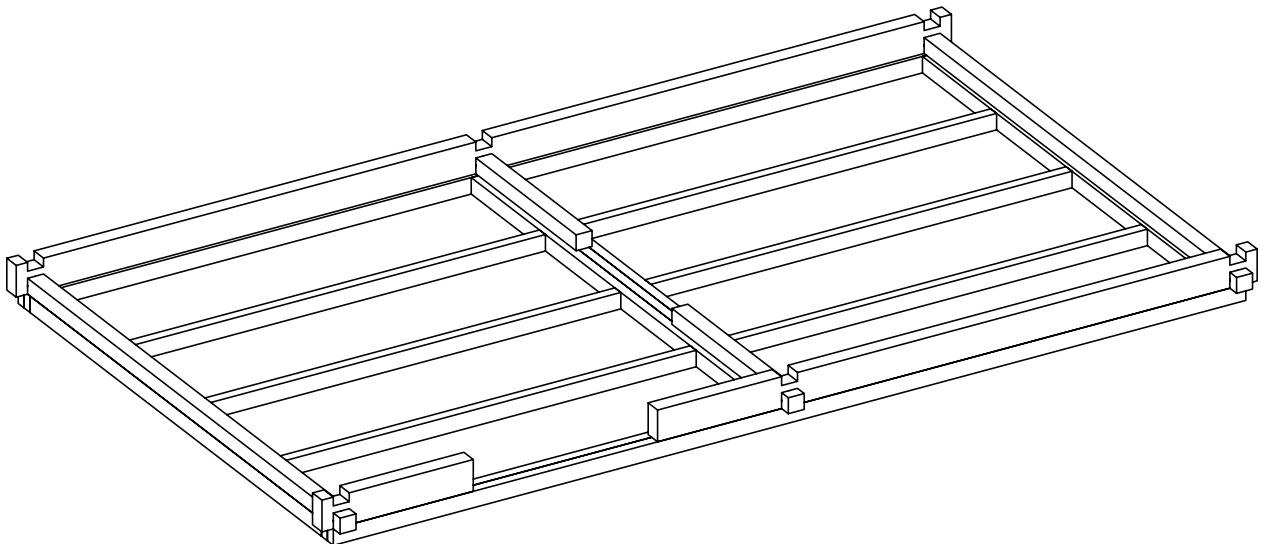
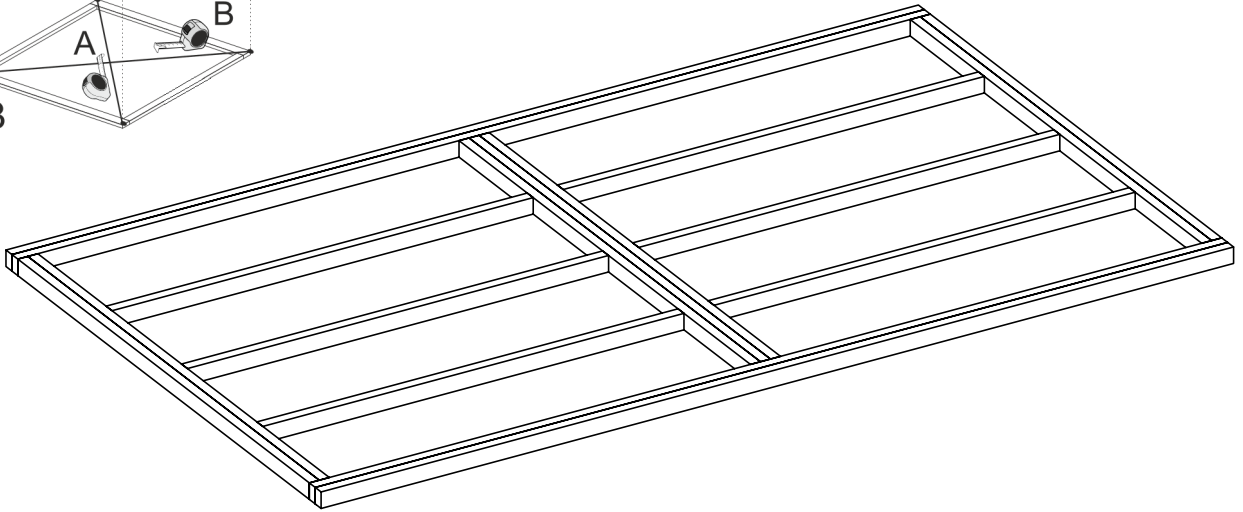

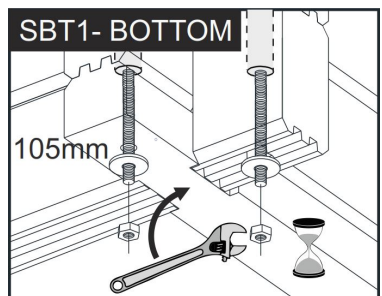
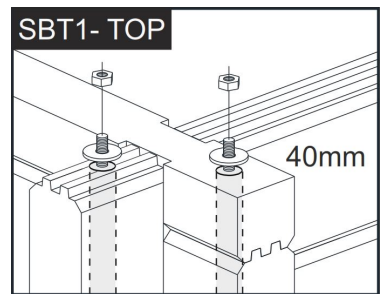
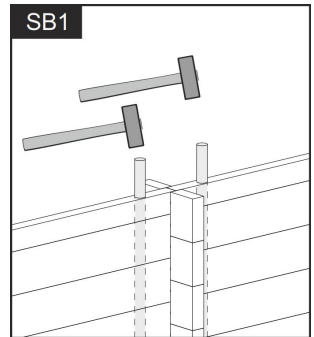
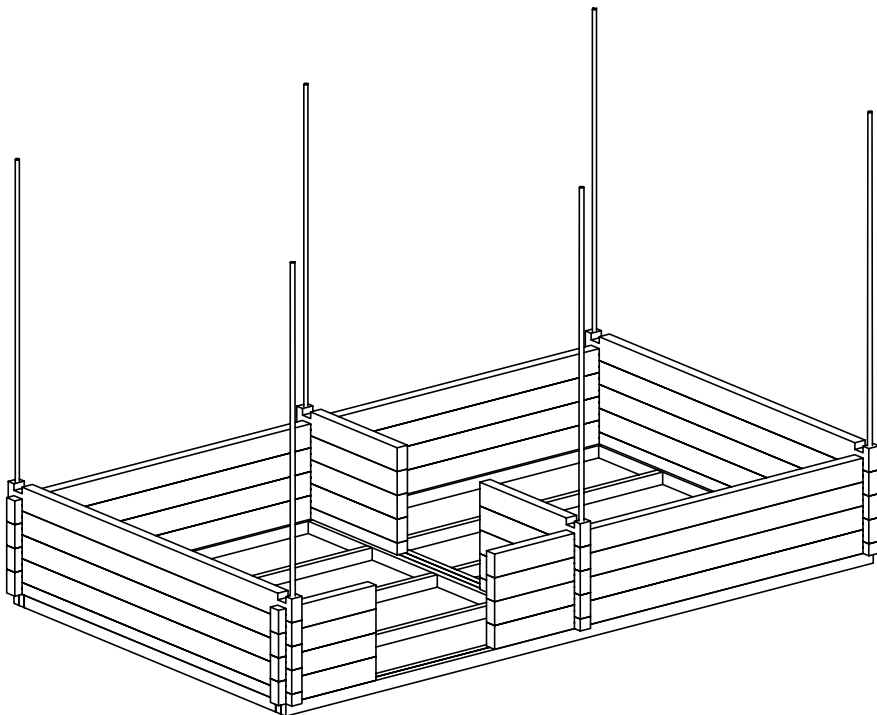
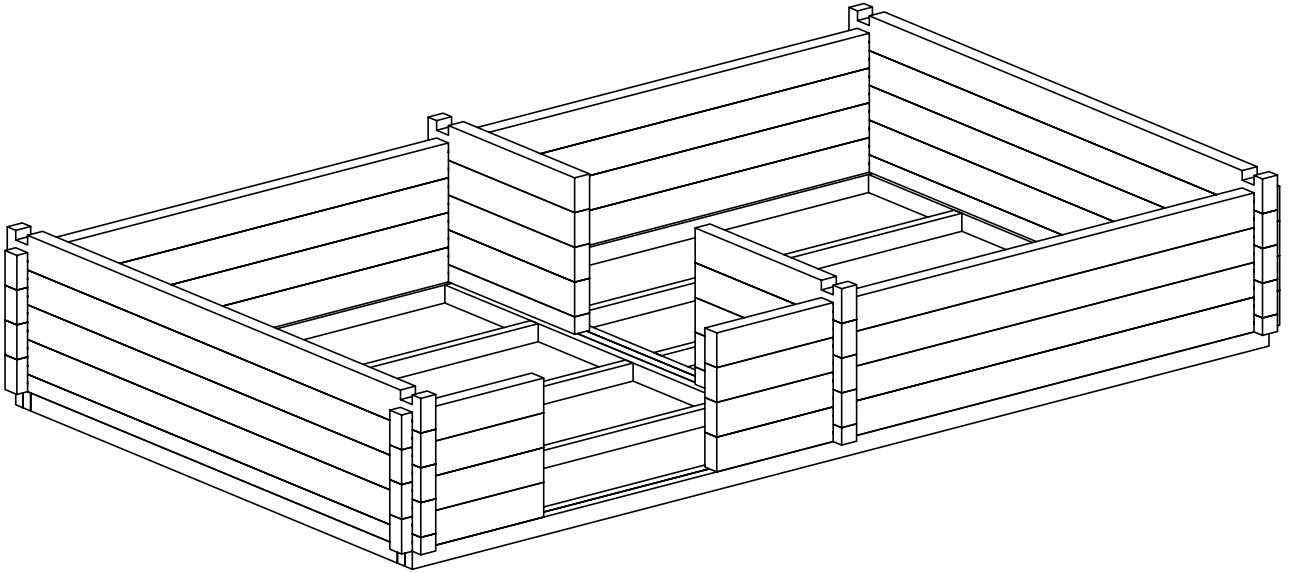

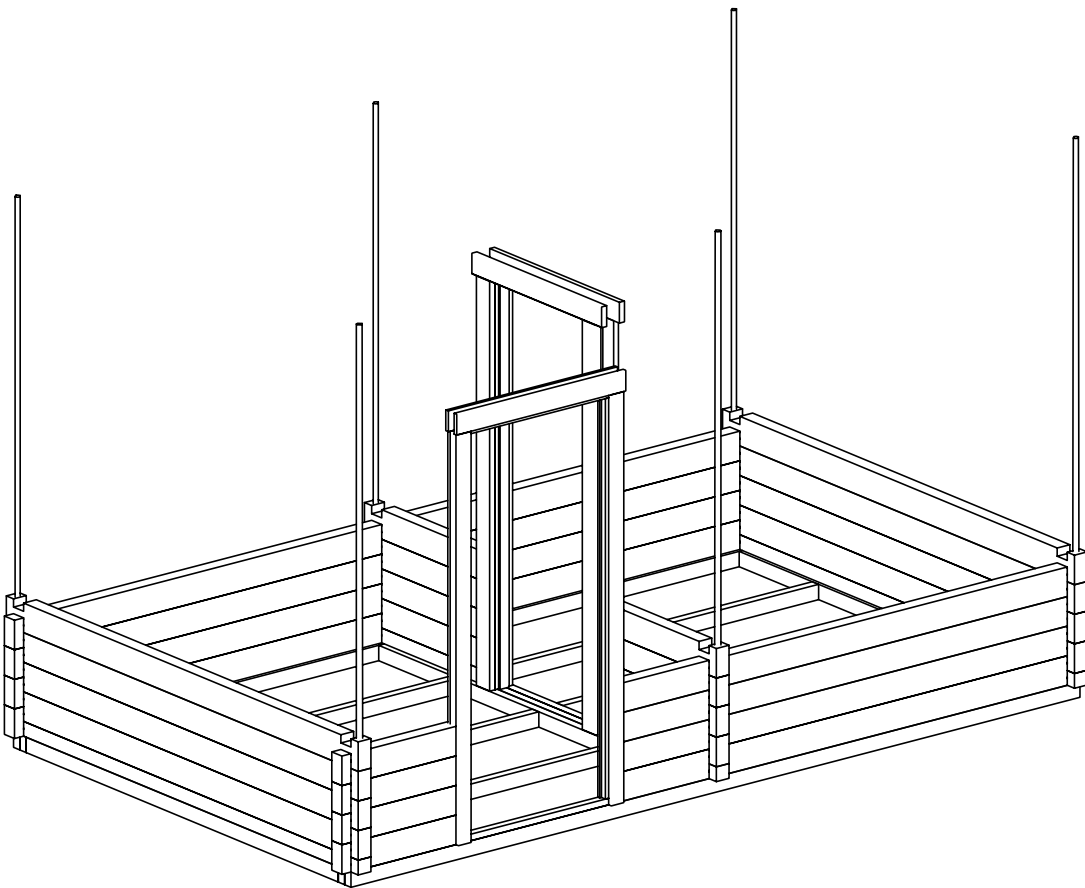
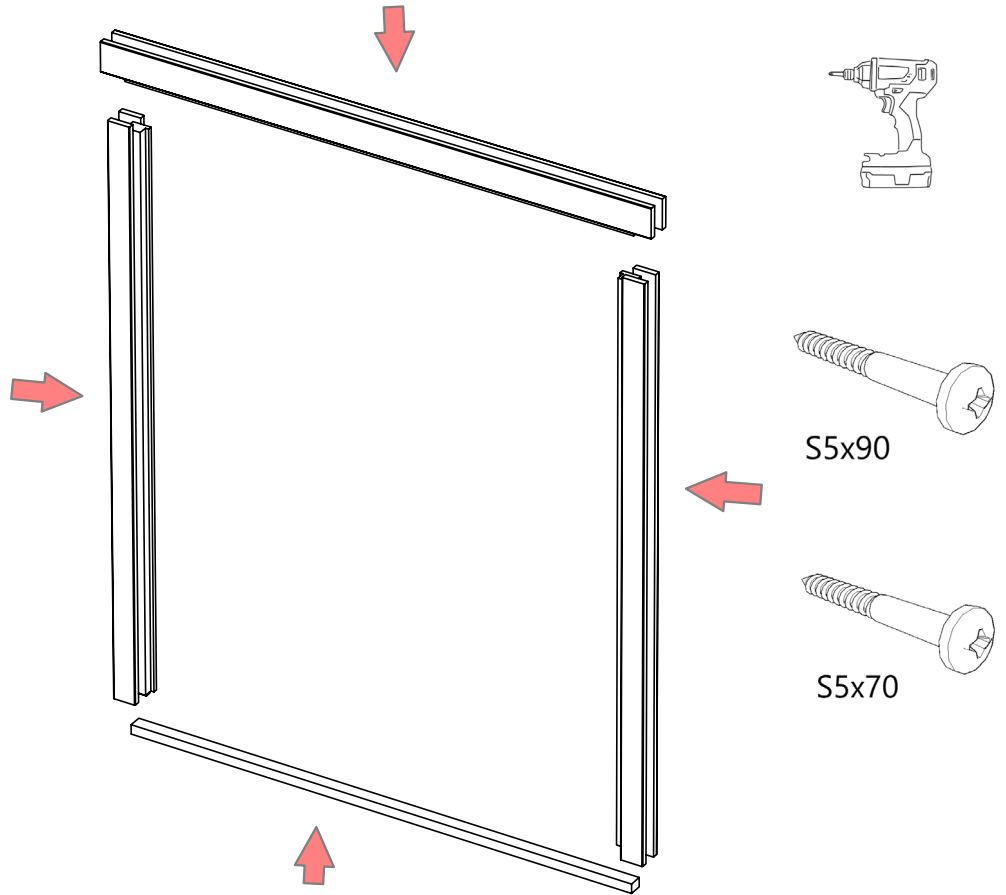

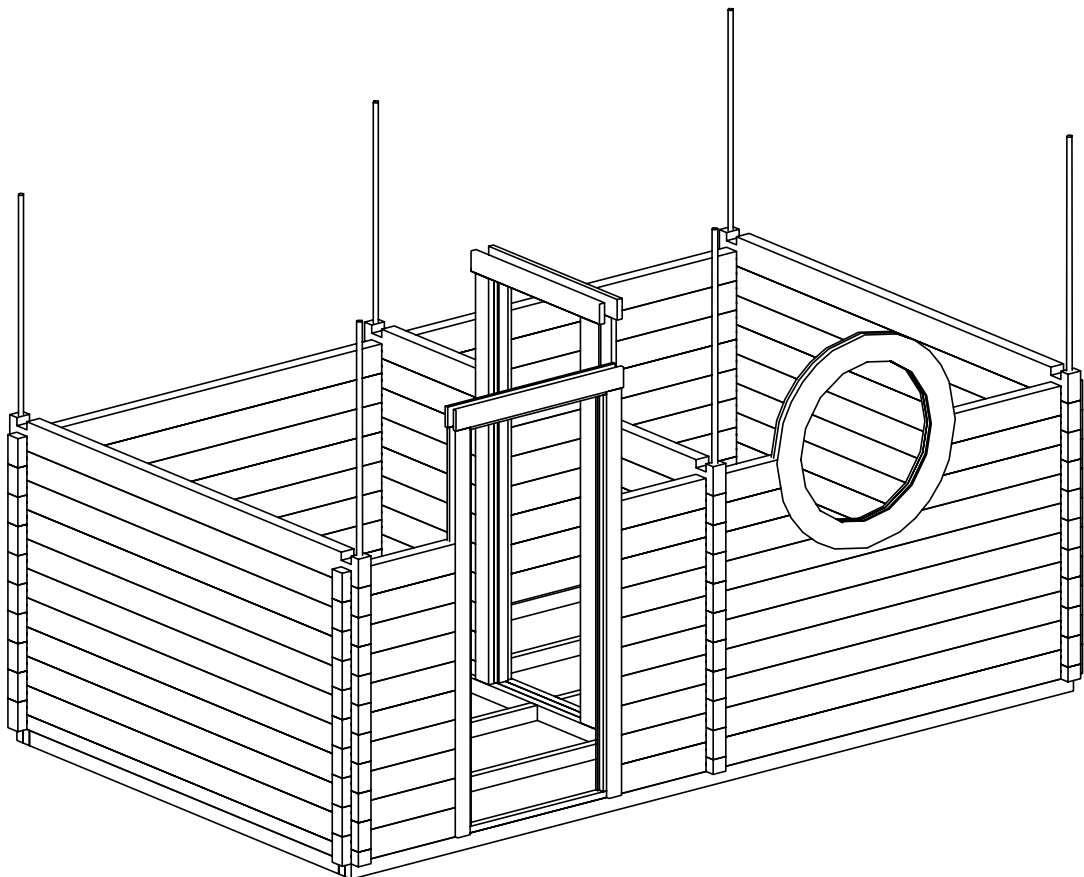
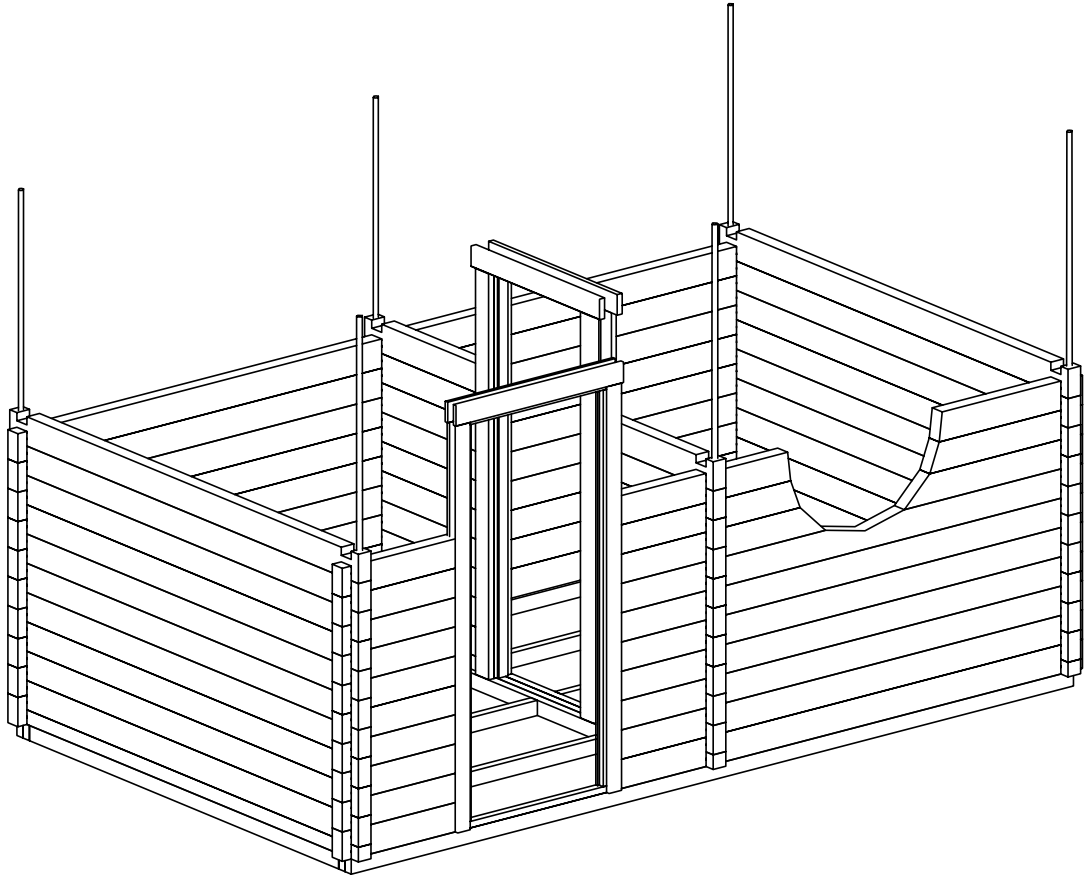

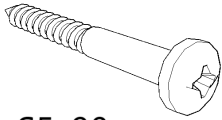
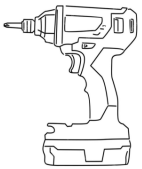
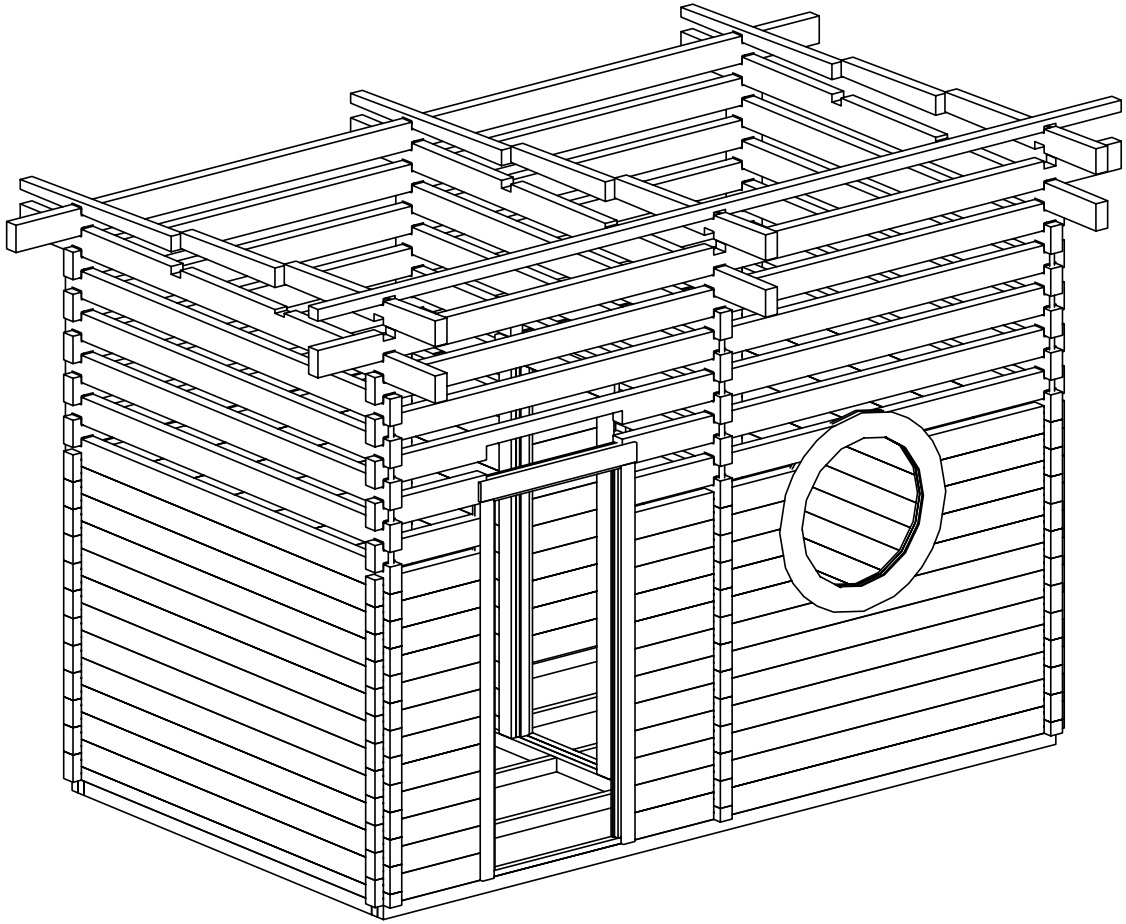

S5x90

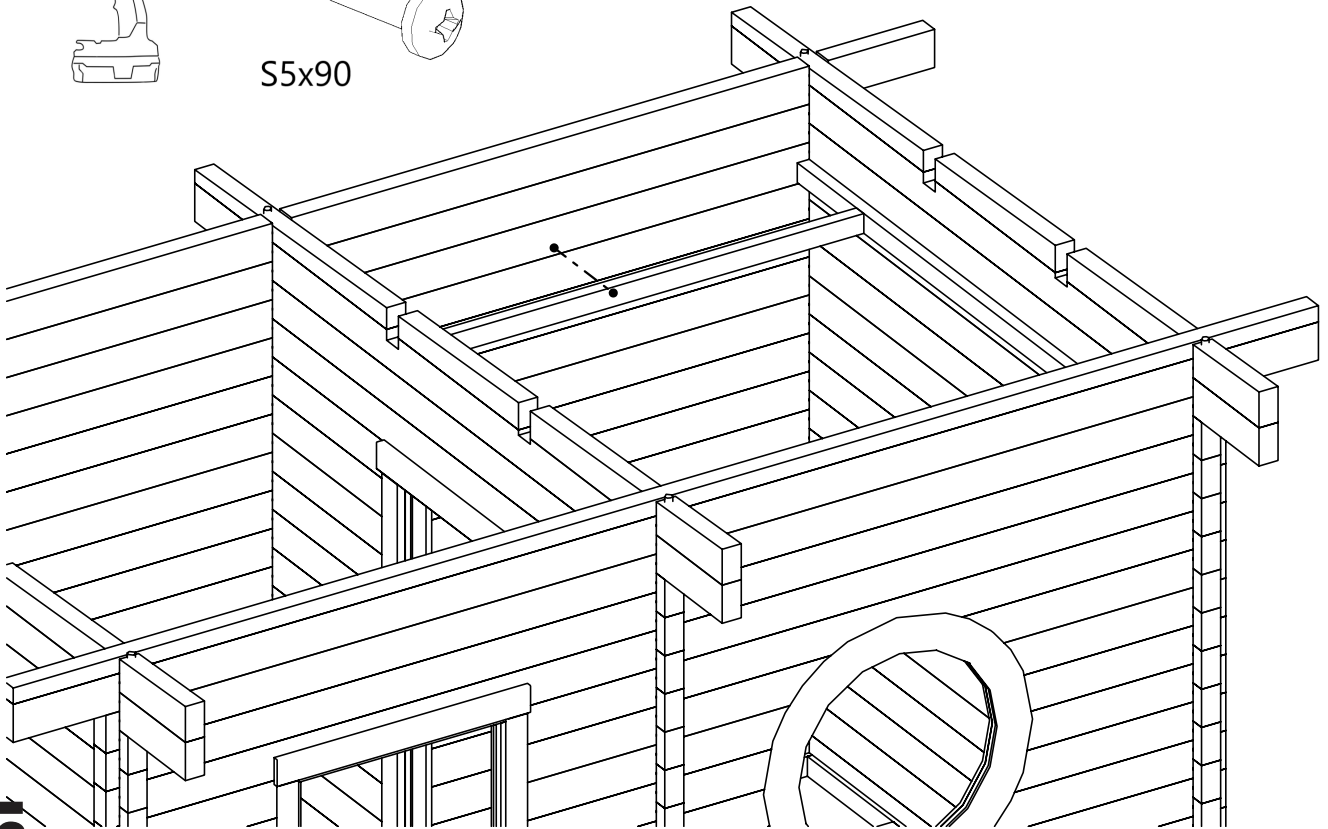

5

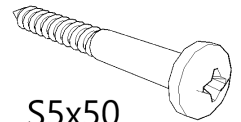
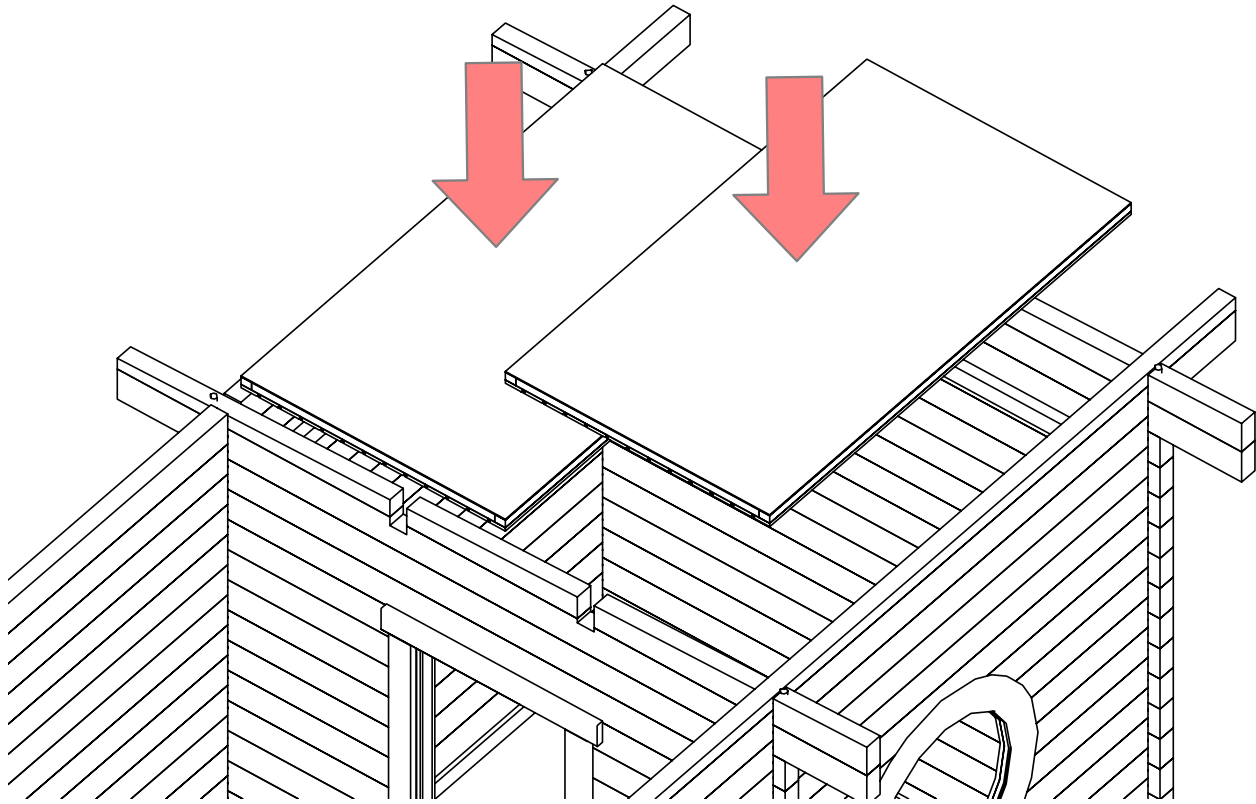

S5x50

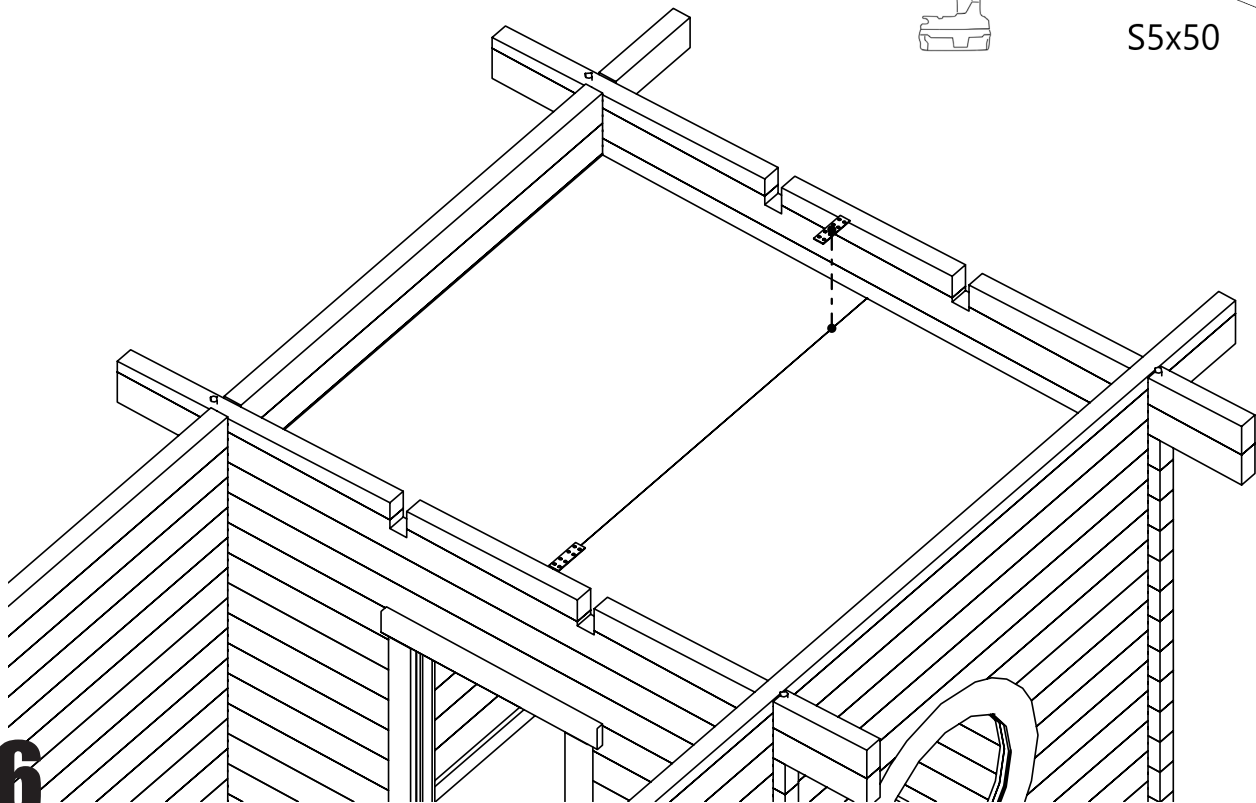

6

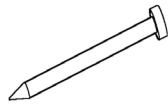
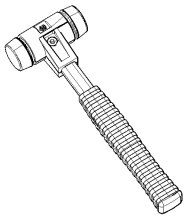
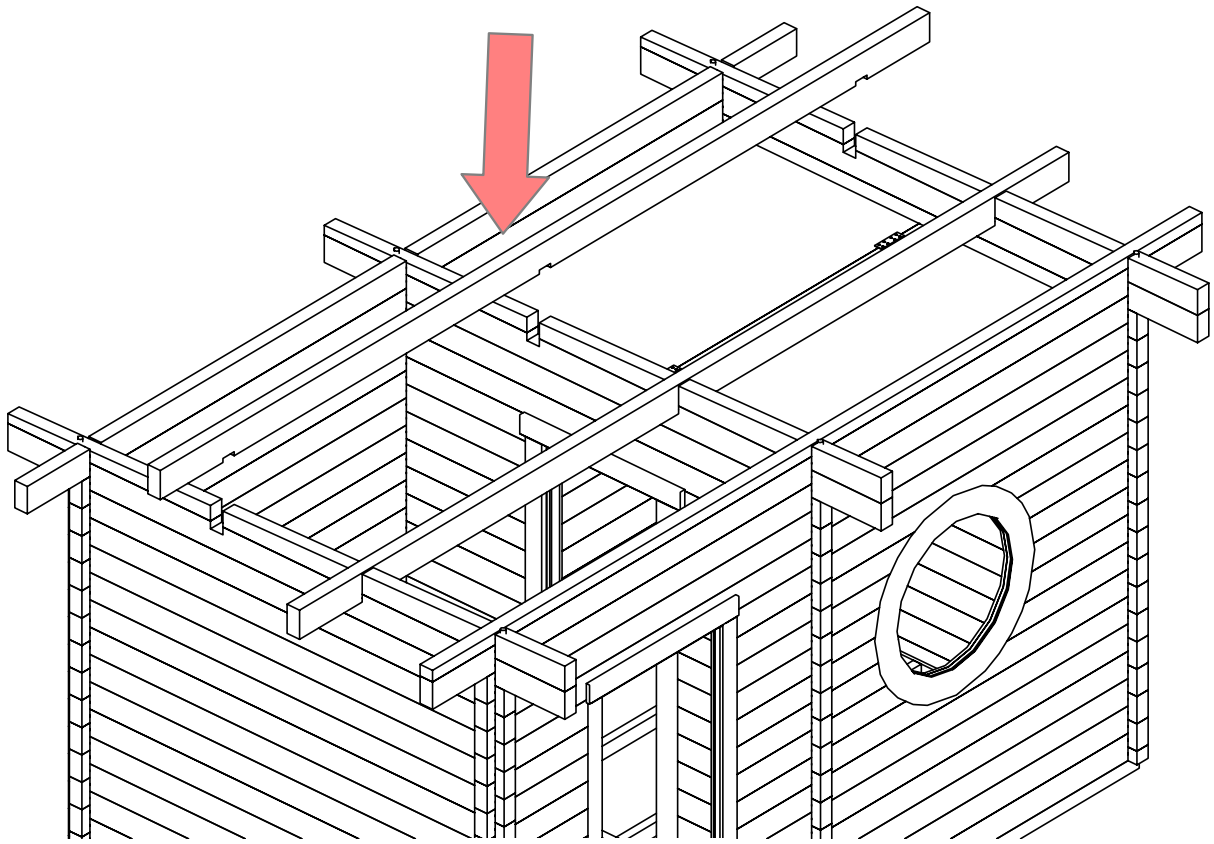

N1,8x40

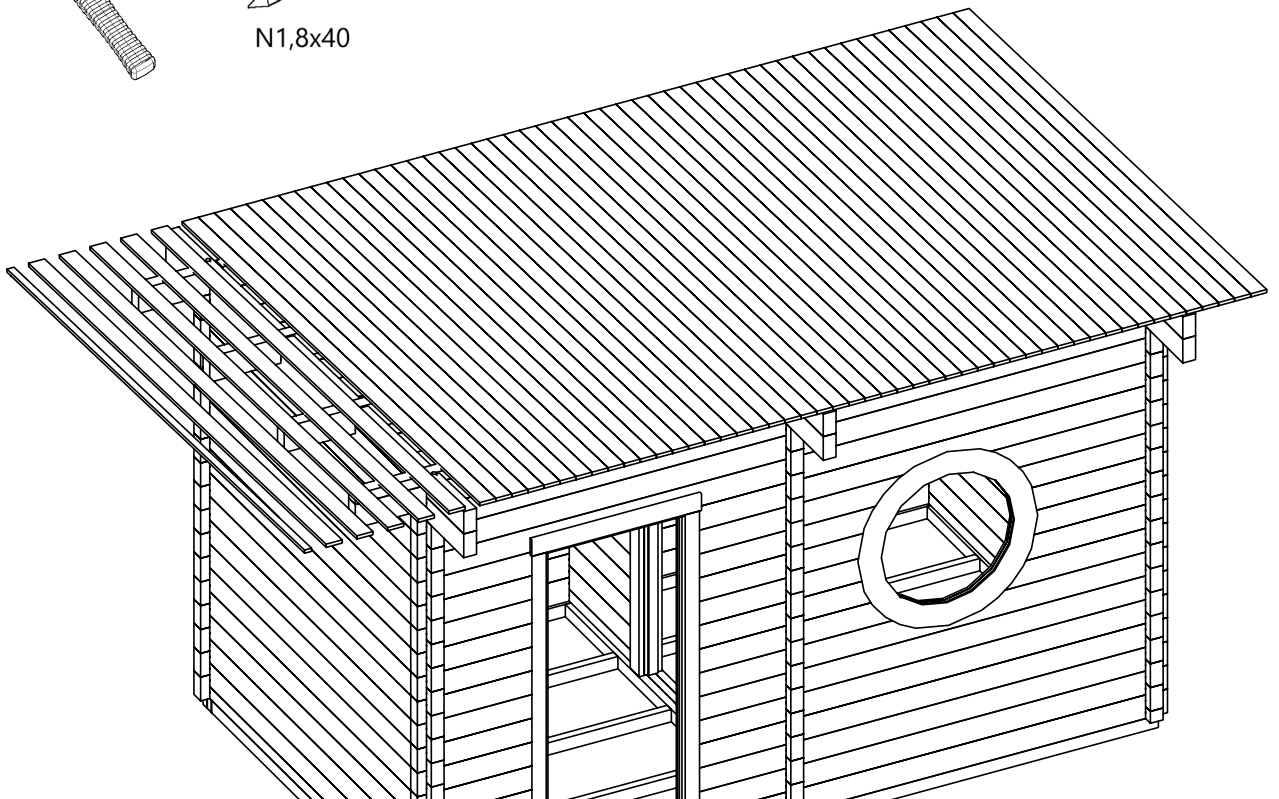
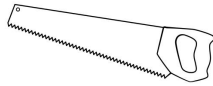

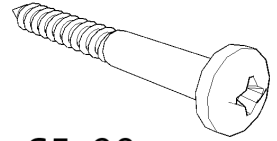
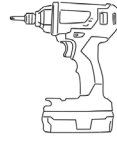

S5x90

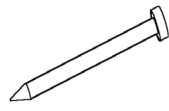
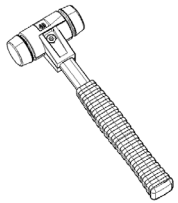
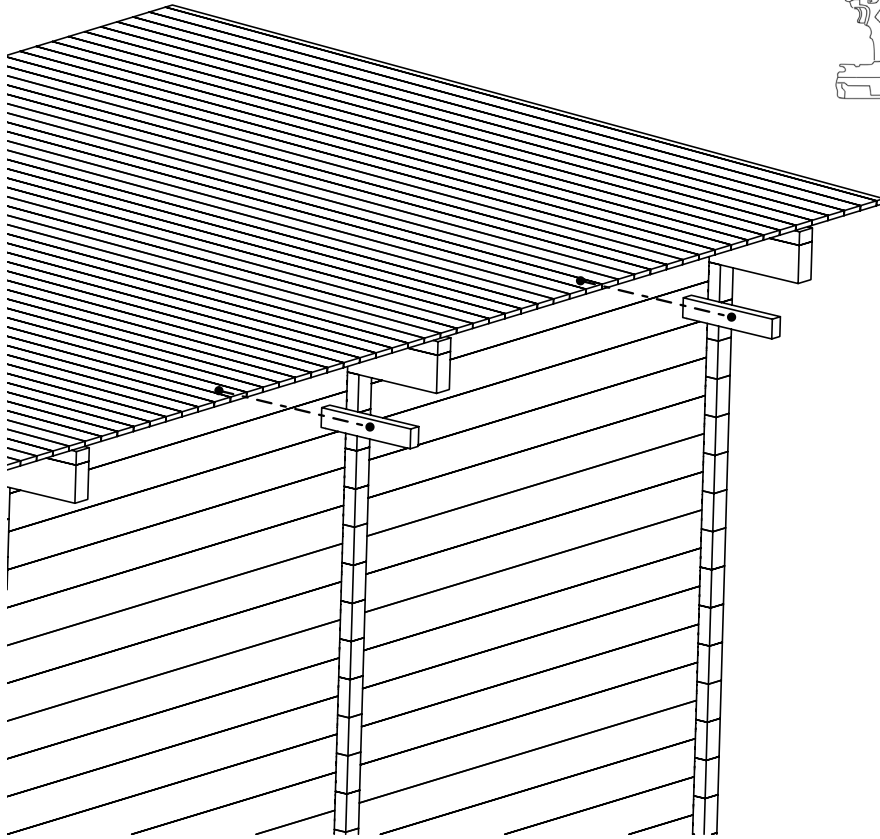

N1,8x40

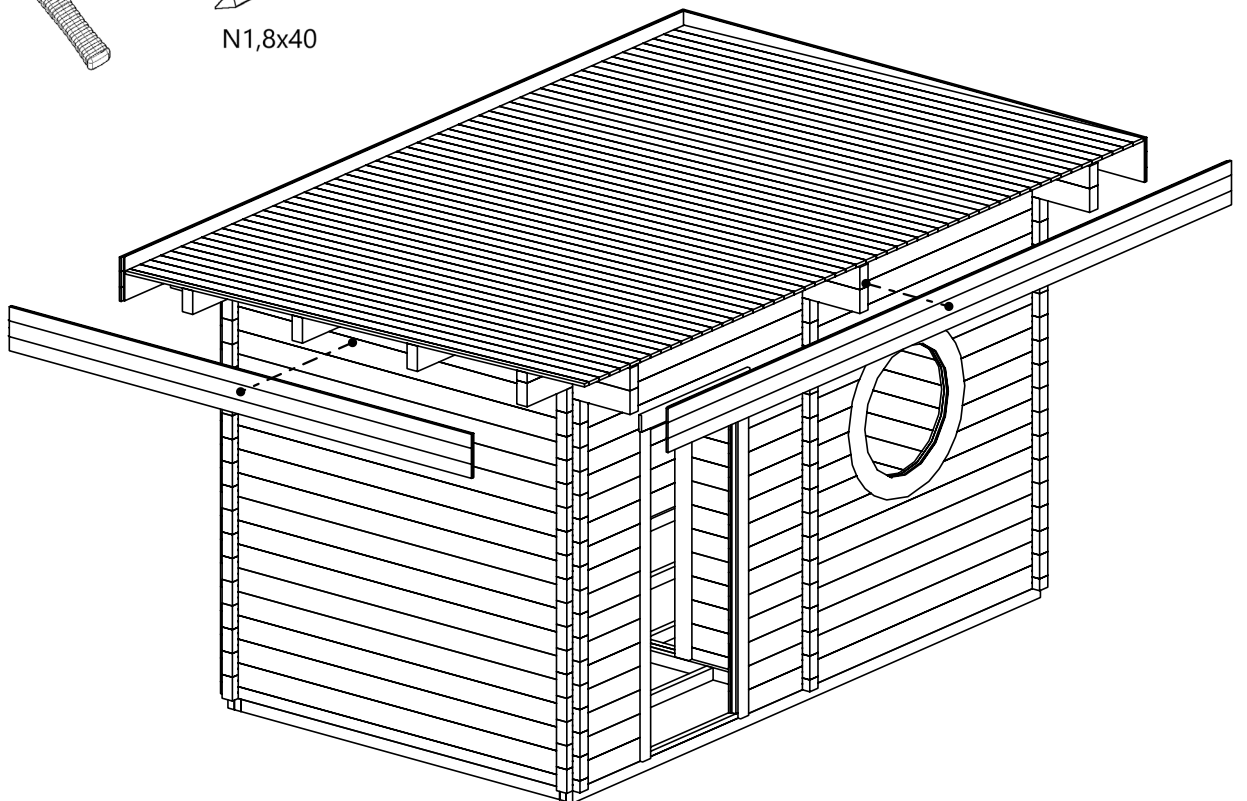

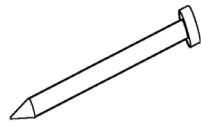
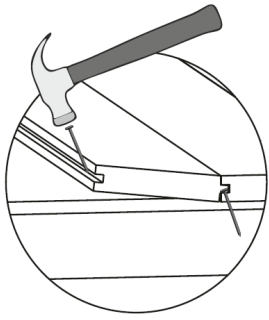

N1,8x40

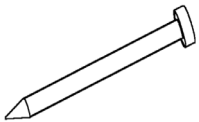
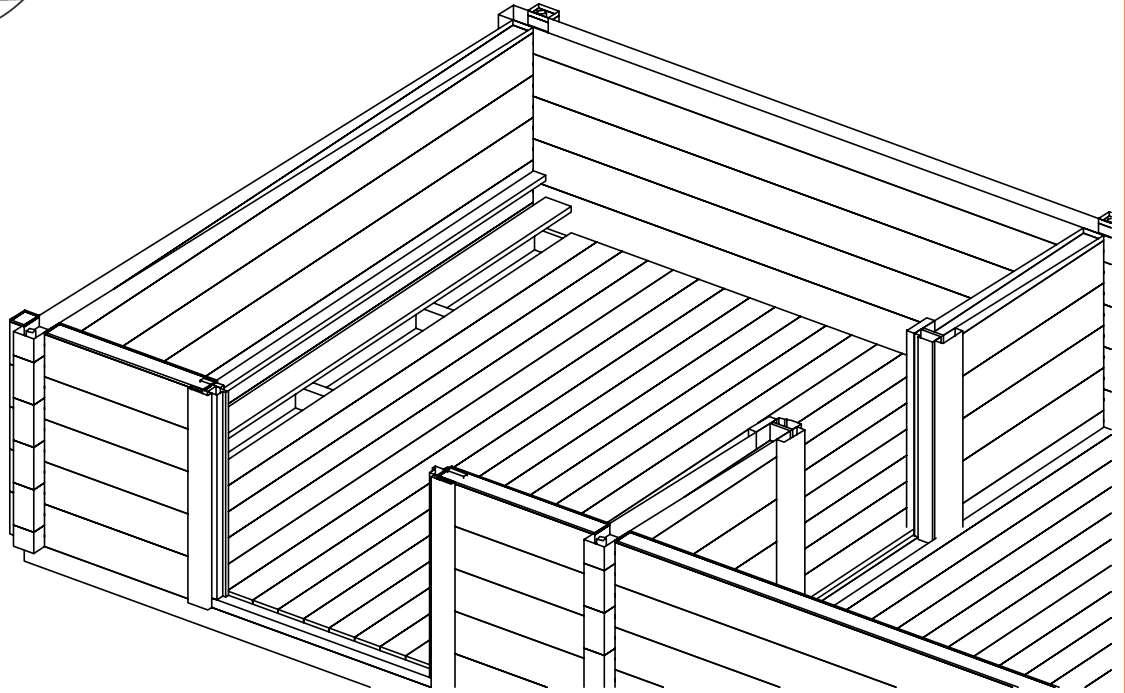
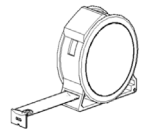
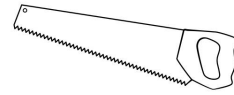

N1,8x40

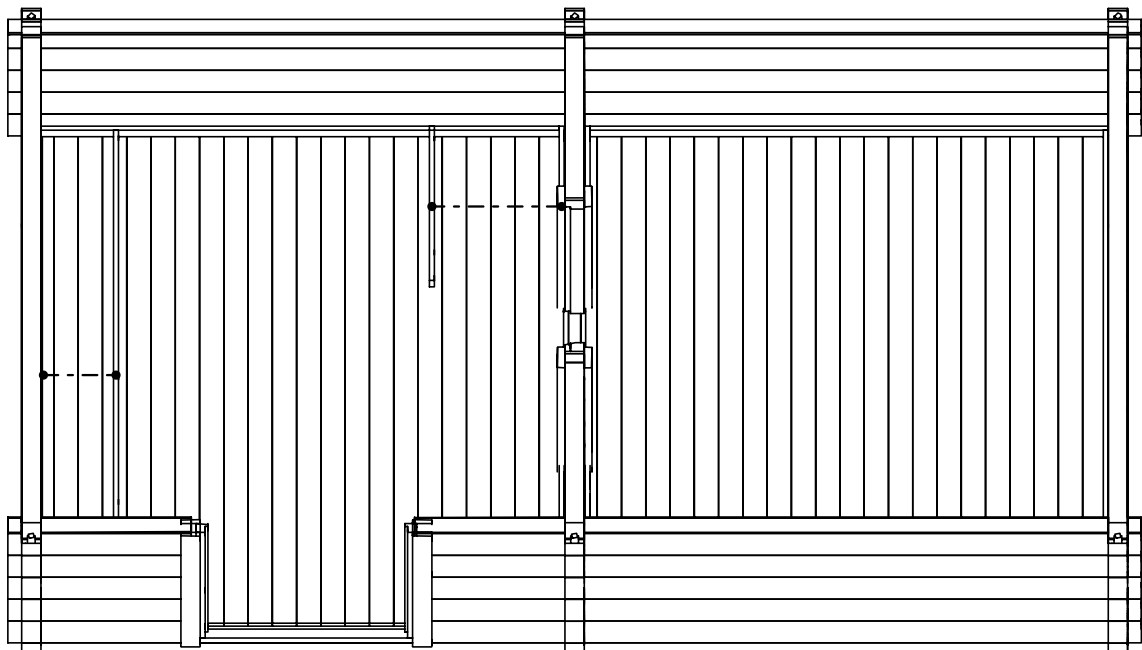
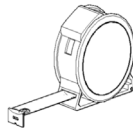
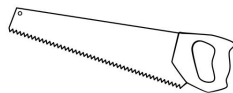

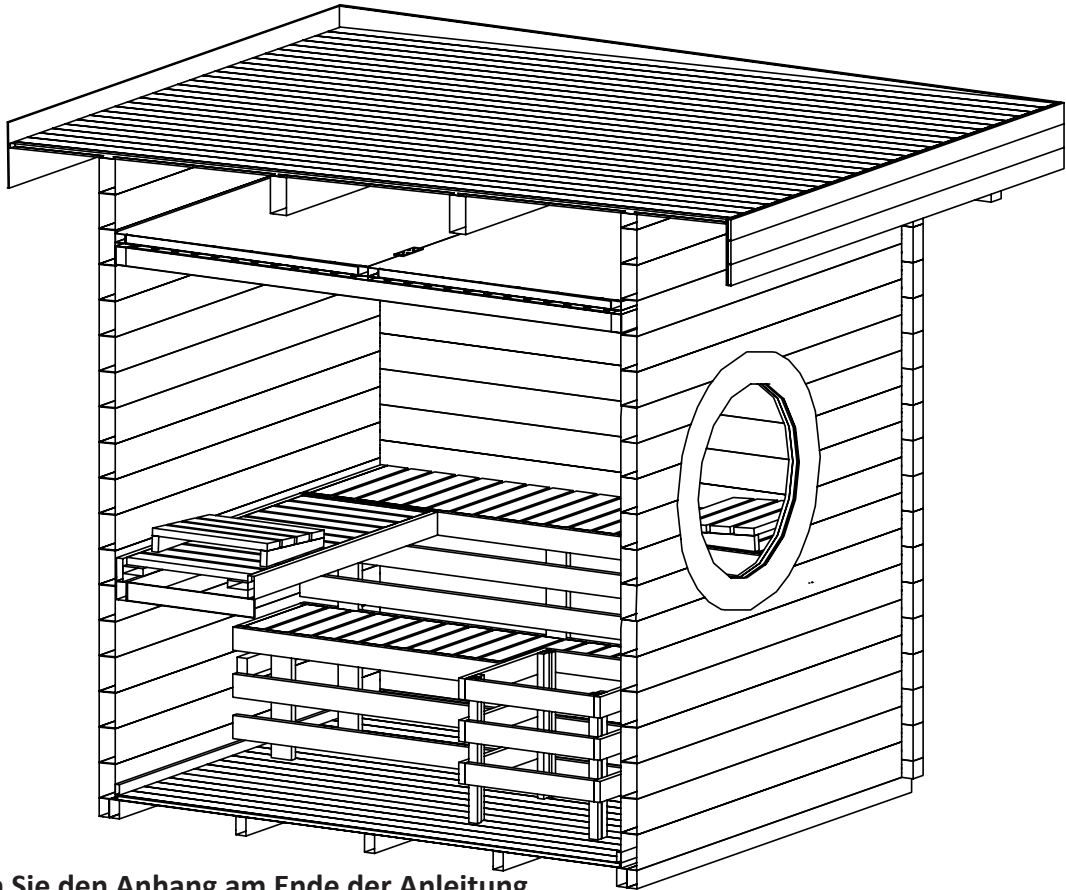

Bitte beachten Sie den Anhang am Ende der Anleitung.
Please refer to the appendix of this section.

Ø ca 130mm

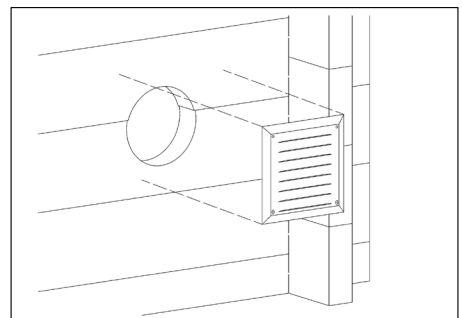
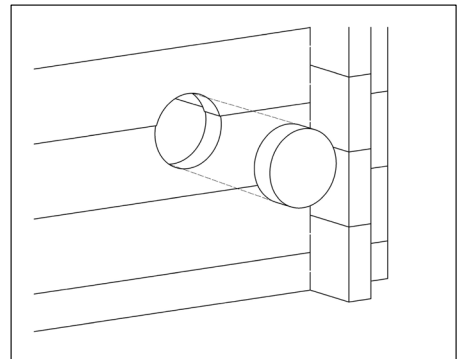
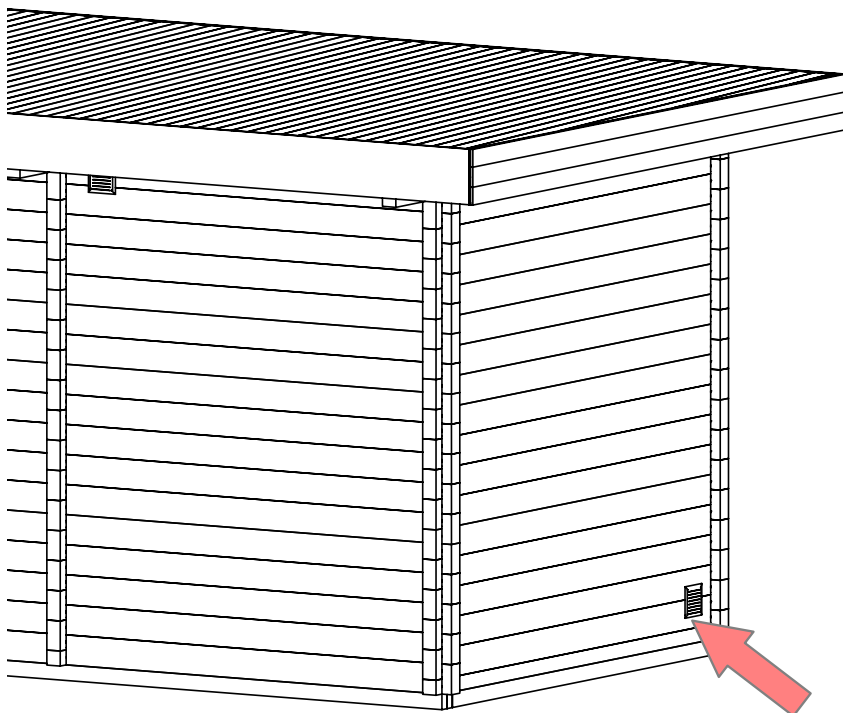
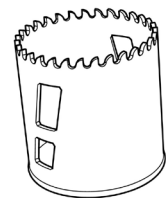
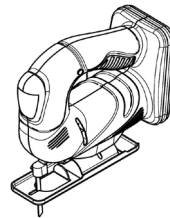

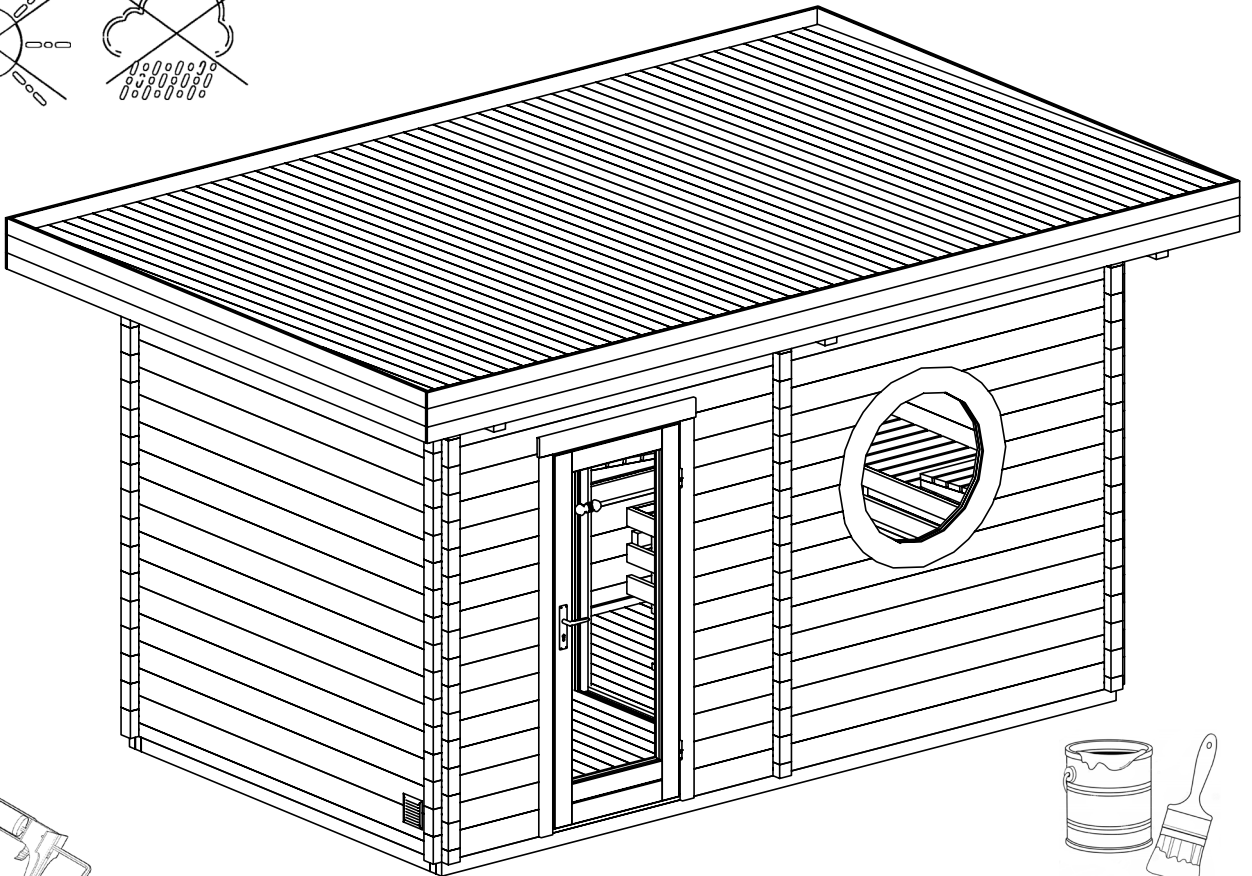
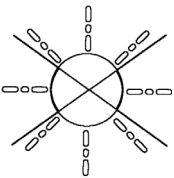
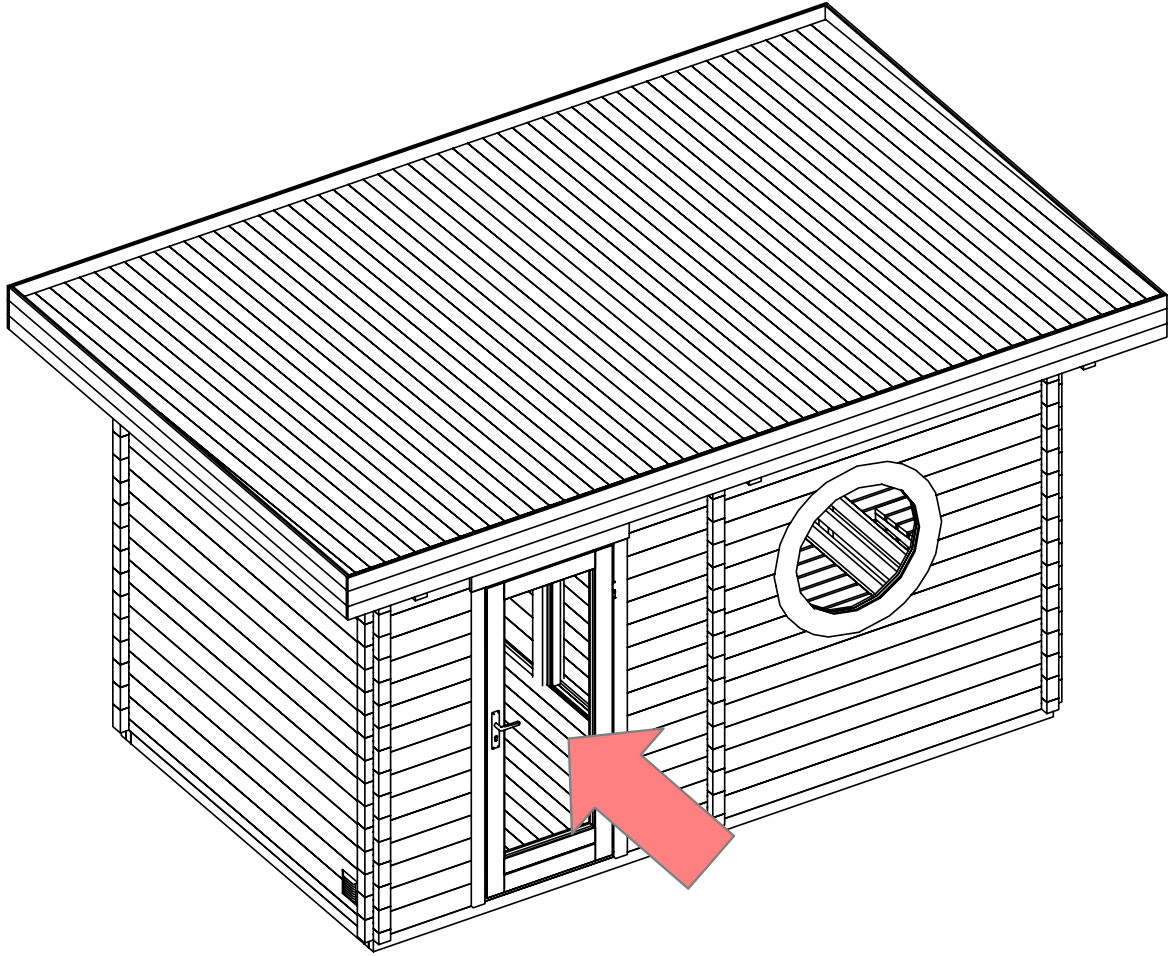

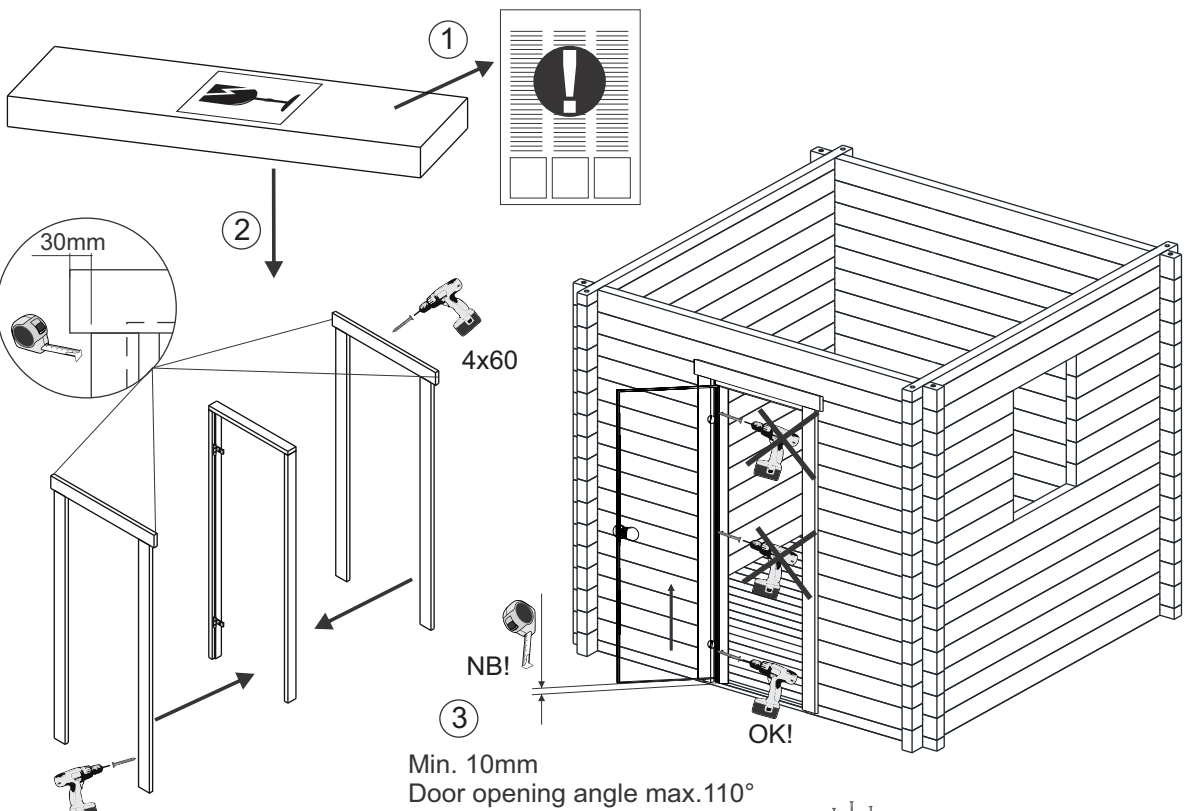

Min. 10mm
Door opening angle max.110°



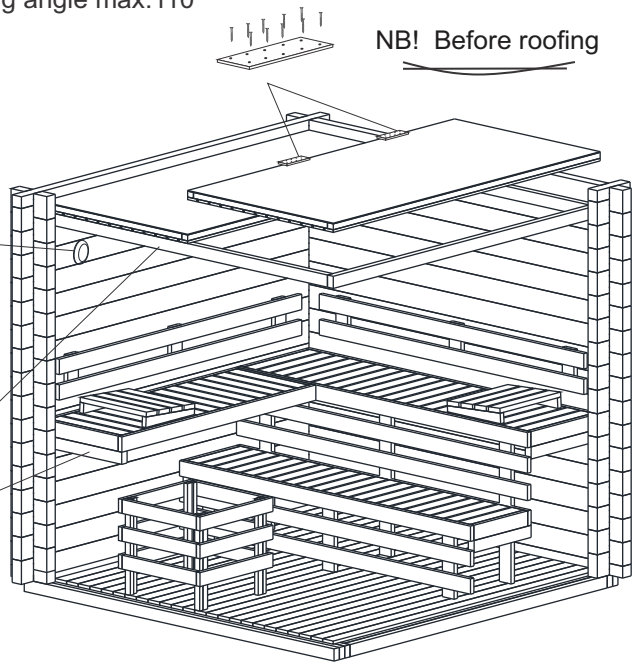
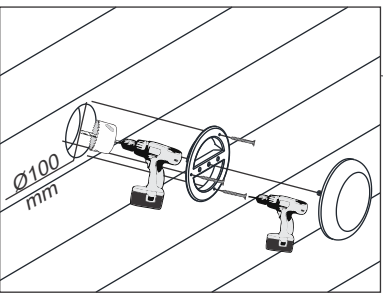

4x60

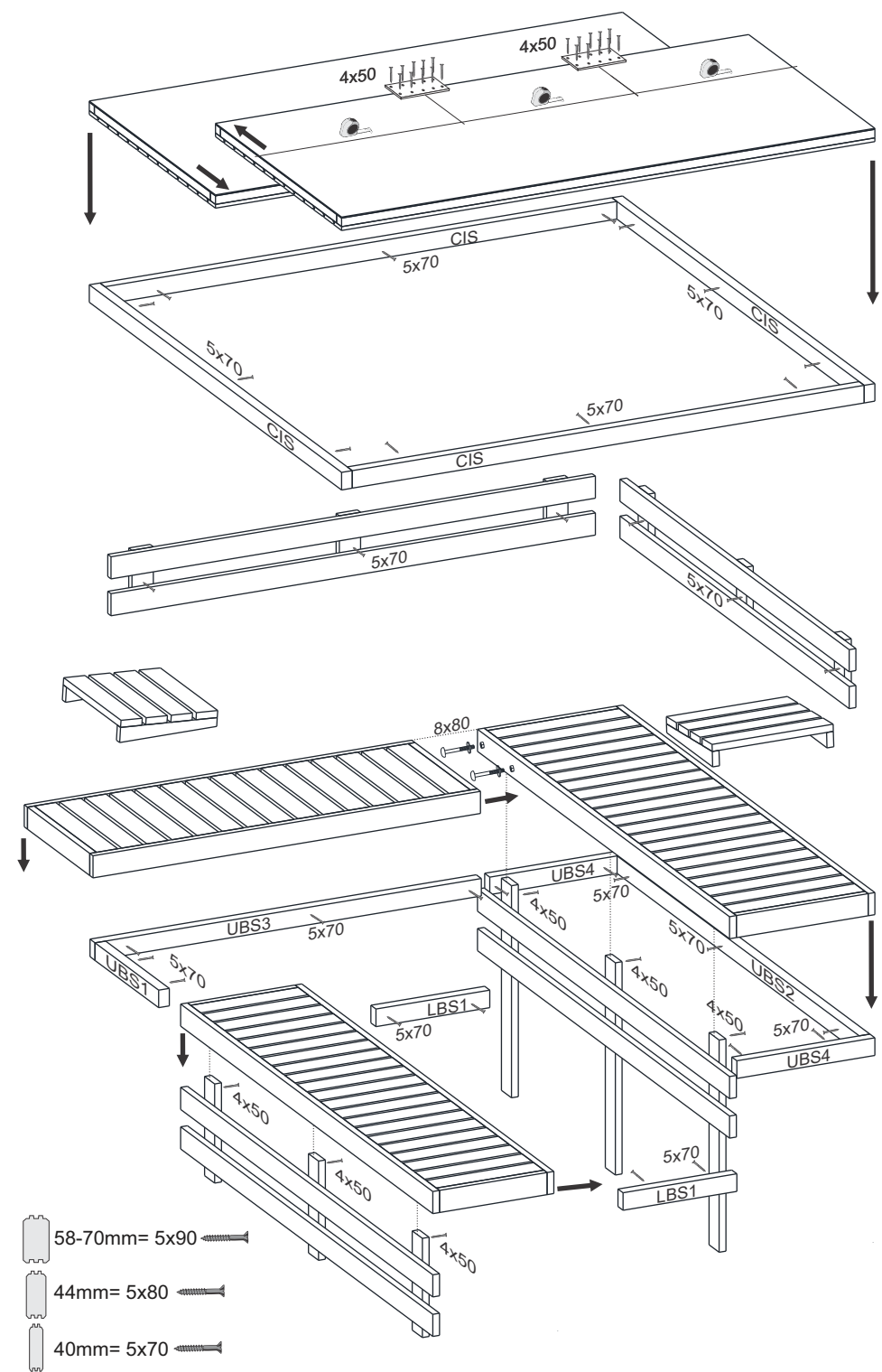



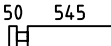
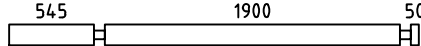

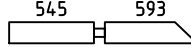
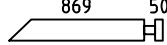
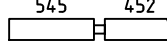
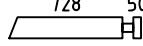
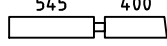
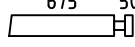
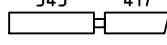
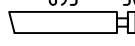
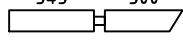
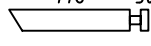
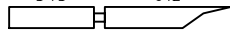
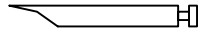
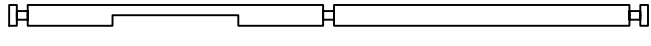
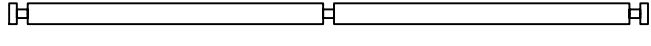
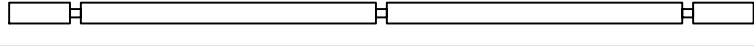

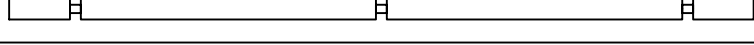
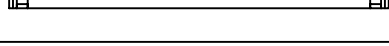
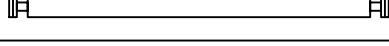
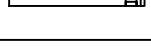

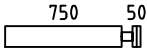
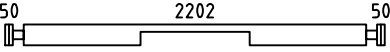
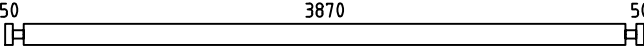
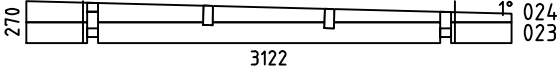
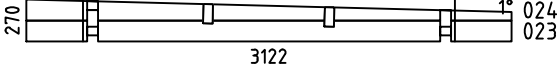
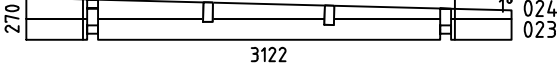
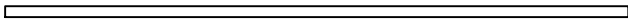
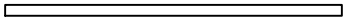

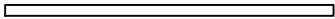





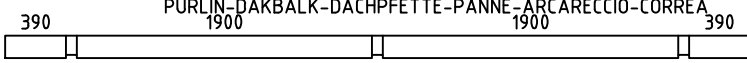







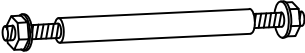

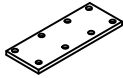
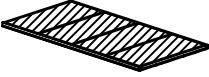
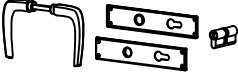

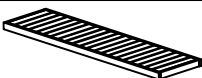
- 58-70mm = 5x90
- 44mm = 5x80
- 40mm = 5x70





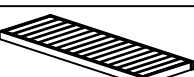
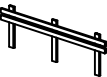

- 58-70mm = 5x90
- 44mm = 5x80
- 40mm = 5x70

Pos	Specification-Spezifikation-Specificatie-Nomenclature-Elementi-Especificacion Sauna Cubus 70 C	Qty	Profile (mm)	Lenght (mm)
001		14	70x135	665
002		7	70x135	2635
003		1	70x135	2635
004		1	70x135	1208
005		1	70x135	989
006		1	70x135	1067
007		1	70x135	848
008		1	70x135	1015
009		1	70x135	795
010		1	70x135	1032
011		1	70x135	813
012		1	70x135	1115
013		1	70x135	896
014		1	70x135	1427
015		1	70x135	1208
016		1	70x135	4110
017		19	70x135	4110
018		1	70x135	4790
019		1	70x58	4790
020		1	70x135	4790
021		2	70x68	2442
022		34	70x135	2442
025		2	70x68	870
Model	Sauna Cubus 70 C	Material	Page 1/4	

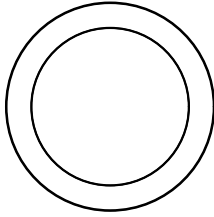
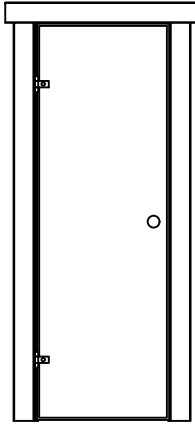
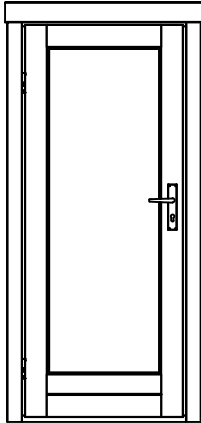
Pos	Specification-Spezifikation-Specificatie-Nomenclature-Elementi-Especificacion Sauna Cubus 70 C	Qty	Profile (mm)	Lenght (mm)
026		26	70x135	870
027		1	70x135	2442
EXTRA		1	70x135	4110
WA-1		1		
WB-1		1		
WC-1		1		
F2	FOUNDATION-FUNDAMENT-FONDATION-FONDAZIONE-VIGAS DE CIMENTACIÓN 	4	44x70	4010
F1	FOUNDATION-FUNDAMENT-FONDATION-FONDAZIONE-VIGAS DE CIMENTACIÓN 	7	44x70	2166
F3	FOUNDATION-FUNDAMENT-FONDATION-FONDAZIONE-VIGAS DE CIMENTACIÓN 	6	44x70	1851
CS1	CORNICE SUPPORT-TRAGELEISTE-STEUNEN BAR-SUPPORT-SUPPORTO-SOPORTE 	2	44x70	390
UBS2	UPPER BENCH SUPPORT-TRAGELEISTE-STEUNEN BAR-SUPPORT-SUPPORTO-SOPORTE 	1	44x70	2112
UBS3	UPPER BENCH SUPPORT-TRAGELEISTE-STEUNEN BAR-SUPPORT-SUPPORTO-SOPORTE 	1	44x70	1293
UBS4	UPPER BENCH SUPPORT-TRAGELEISTE-STEUNEN BAR-SUPPORT-SUPPORTO-SOPORTE 	2	44x70	570
UBS1	UPPER BENCH SUPPORT-TRAGELEISTE-STEUNEN BAR-SUPPORT-SUPPORTO-SOPORTE 	1	44x70	555
LBS1	LOWER BENCH SUPPORT-TRAGELEISTE-STEUNEN BAR-SUPPORT-SUPPORTO-SOPORTE 	2	44x70	470
CIS1	CEILING INSULATION SUPPORT-TRAGELEISTE-STEUNEN BAR-SUPPORT-SUPPORTO-SOPORTE 	2	44x70	2202
CIS2	CEILING INSULATION SUPPORT-TRAGELEISTE-STEUNEN BAR-SUPPORT-SUPPORTO-SOPORTE 	2	44x70	1812
PL1	PURLIN-DAKBALK-DACHPFETTE-PANNE-ARCARECCIO-CORREA 	2	70x144	4790
F-1	Floor board-Fussbodenbrett-Vloerplank-Lame de plancher-Tavola pavimento-Tabla de suelo 	44 34	88x18 114x18	2192
R-1	Roof board-Dachbrett-Dakplank-Volige-Tavola tetto-Tabla de tejado 	55+1 43+1	88x18 114x18	3120
CO-1	Cornice 20x250-Gesimse-Kroonlijst-Corniche-Cornicione-Cornisa 	2	20x250	3136
CO-2	Cornice 20x250-Gesimse-Kroonlijst-Corniche-Cornicione-Cornisa 	2	20x250	4830
FLB-1	Floor beading 3000-Fussbodenleiste-Plinten-Moulure de finition-Listello pavimento-Liston de suelo 	8	18x40	24rmt.
Model	Sauna Cubus 70 C	Material	Page	2/4

Pos	Specification-Spezifikation-Specificatie-Nomenclature-Elementi-Especificacion Sauna Cubus 70 C	Qty	Profile (mm)	Lenght (mm)
TSB1	Threaded steel bar kit-Gewindestange satz-Draadstang set-Kit de tiges filetées-Kit barra filettata-Kit barra roscada 	6	14	2535
	Backrest-Rückenlehne-Rugleuning-Dossier-Schienale-Respaldo 	1	235x1700	
	Backrest-Rückenlehne-Rugleuning-Dossier-Schienale-Respaldo 	1	235x2000	
	Bracket 140x40-Lochplatte-Gatenplaat-Connecteur métallique-Piastre forate-Placas perforadas 	2	140x40	
CI	Ceiling Insulation-Deckelsolation-Plafondisolatie-Isolation du plafond-Isolamento del soffitto-Aislamiento de techo 	2	1890x1095	
	Door kit-Tür satz-Deur set-Kit porte-Kit porta-Kit para puerta 	1		
	Headrest-Kopfstütze-Hoofdsteun-Appui-tête-Poggiatesta-Reposacabezas 	2	395x395	
	Heater guard-Heizungsschutz-Verwarmingsbescherming-Protection de radiateur-Protezione del riscaldatore-Protector de calentador 	1	562x602	
	Lower Bench-Untere Bank-Onderbank-Banc inférieur-Banco inferiore-Banco inferior 	1	500x2200	
	Lower bench face-Bank unterstützung-Bankje ondersteuning-Dossier banc-Banco schienale-Banco respaldo 	1	395x2200	
	Nail 1.8x40-Nagel-Spijker-Clou-Chiodo-Clavo 	440	1.8x40	
R8x80	Round head bolt kit 8x80-Schloßschraube-Slotbout-Boulon tête ronde-Bulloni testa tonda-Tornillo cabeza redonda 	2	8x80	
	Sauna ventilation kit-Außengitter-Schoepenrooster-Panneau de ventilation-Griglia di ventilazione-Rejilla de ventilacion 	1		
S4x50	Screw 4x50-Schraube-Schroef-Vis-Vite-Tornillo 	6	4x50	
S5x90	Screw 5x90-Schraube-Schroef-Vis-Vite-Tornillo 	30	5x90	
S6x120	Screw 6x120-Schraube-Schroef-Vis-Vite-Tornillo 	30	6x120	
	Upper bench 2-Obere Bank-Bovenbank-Banc supérieur-Banco superiore-Banco superior 	1	600x1300	
	Upper bench face-Bank unterstützung-Bankje ondersteuning-Dossier banc-Banco schienale-Banco respaldo 	1	845x2200	
	Upper bench-Obere Bank-Bovenbank-Banc supérieur-Banco superiore-Banco superior 	1	600x2200	
	Ventilation panel kit-Außengitter-Schoepenrooster-Panneau de ventilation-Griglia di ventilazione-Rejilla de ventilacion 	1		
Model	Sauna Cubus 70 C	Material	Page	3/4

Pos	Specification-Spezifikation-Specificatie-Nomenclature-Elementi-Especificacion Sauna Cubus 70 C	Qty	Profile (mm)	Lenght (mm)
	<p>WINDOW 860x860 WR 860x860-70 ISO TEMPERED</p> 	1		
	<p>DOOR 690x1900 SD Sauna 690x1900-70 L</p> 	1		
	<p>DOOR 800x1900 SD08 F 800x1900-70 ISO L</p> 	1		
	<p>Sauna door trim board</p> 	2	28x95	900
	<p>Sauna door trim board</p> 	4	28x95	1850
	<p>Screw 4x50-Schraube-Schroef-Vis-Vite-Tornillo</p> 	25	4x60	
Model	Sauna Cubus 70 C	Material	Page 4/4	

H = 1.600 m
TOTAL: 8.37 m²

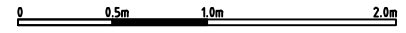
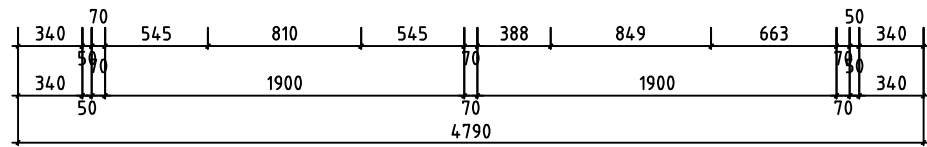
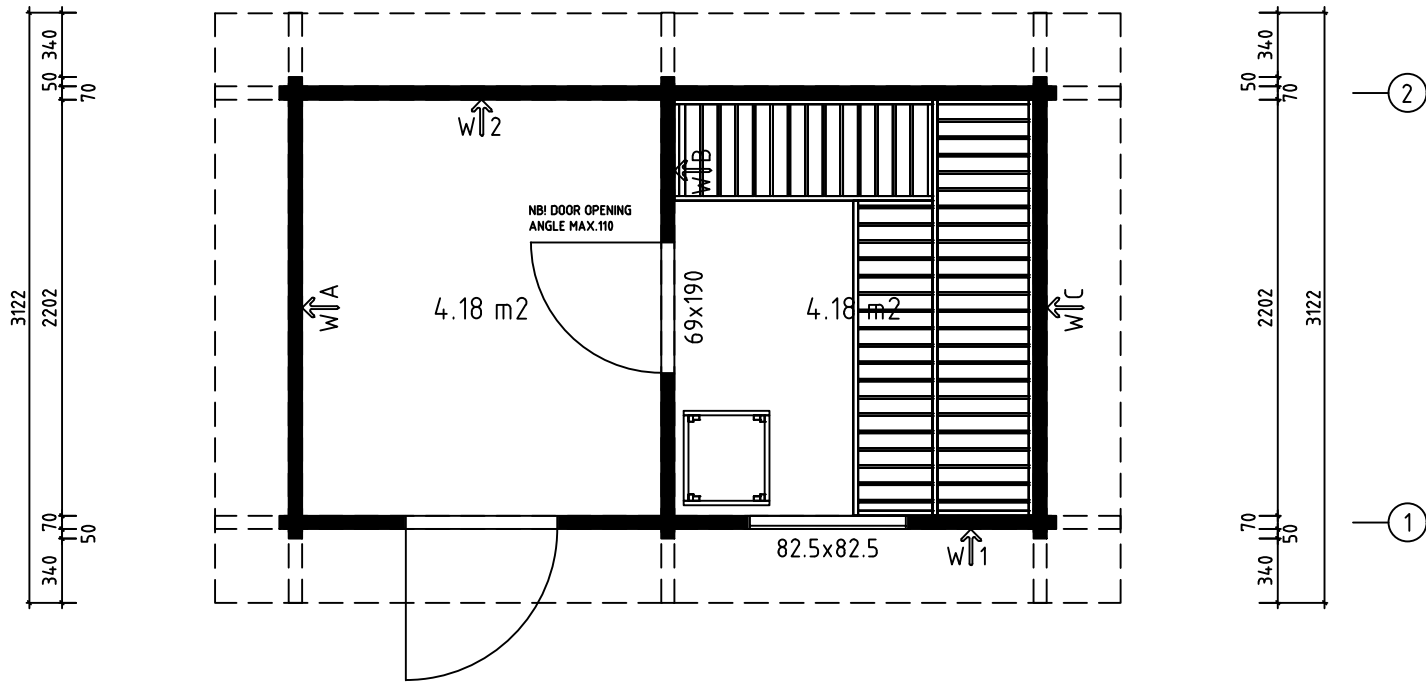
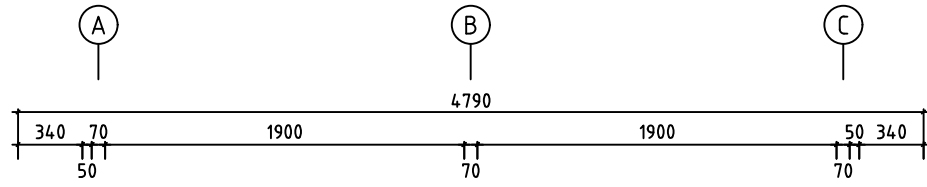

Model	Sauna Cubus 70 C		Drawing	PLAN	Page
	Drawn by	R.T	Material	70x135	Scale
	Date	09.04.2024	File	Sauna Cubus 70 C.dwg	

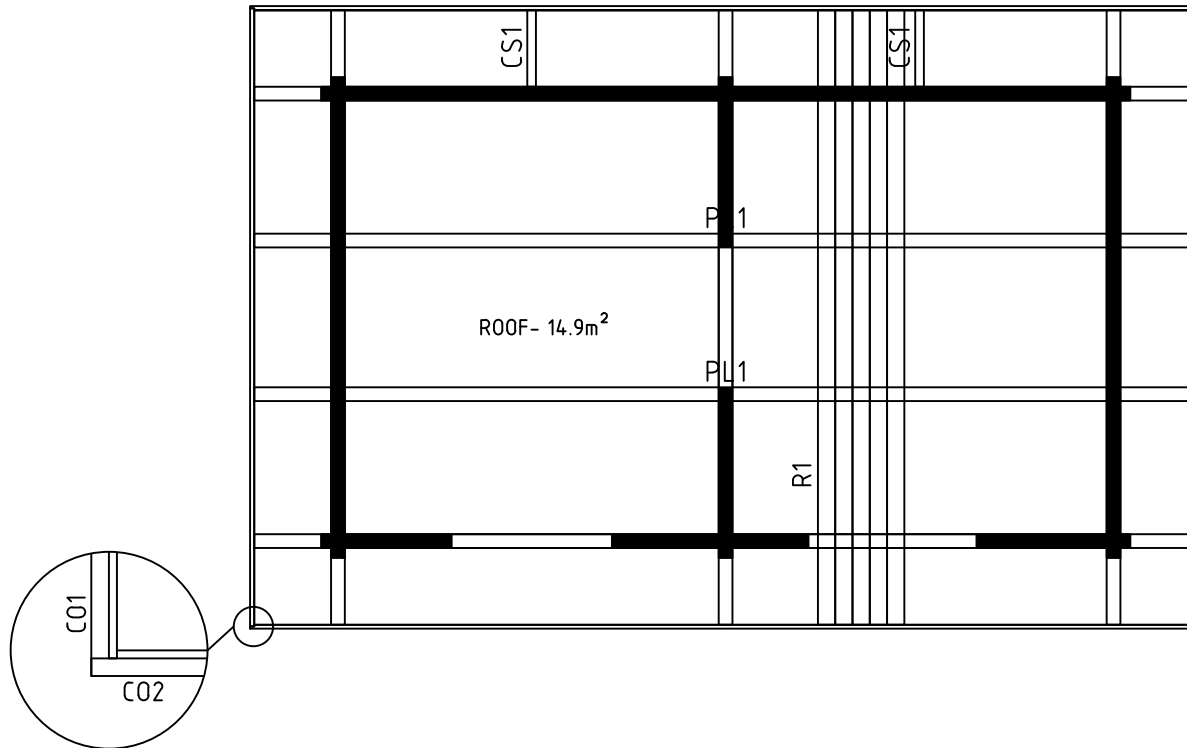

0 0.5m 1.0m 2.0m

Model	Sauna Cubus 70 C		Drawing	ROOF	Page
	Drawn by	R.T	Material	70x135	Scale
	Date	09.04.2024	File	Sauna Cubus 70 C.dwg	

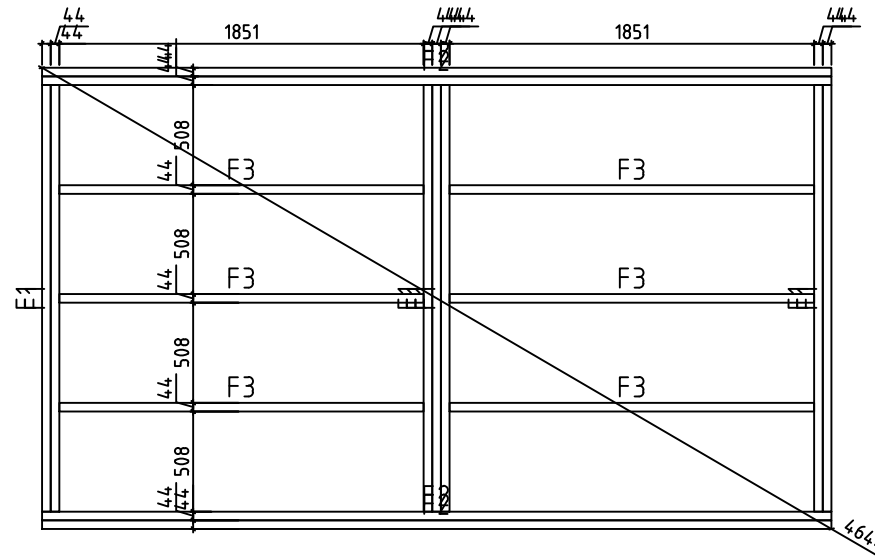

0 0.5m 1.0m 2.0m

Model	Sauna Cubus 70 C		Drawing	FOUNDATION		Page	
	Drawn by	R.T	Material	70x135		Scale	1:40
	Date	09.04.2024	File	Sauna Cubus 70 C.dwg			

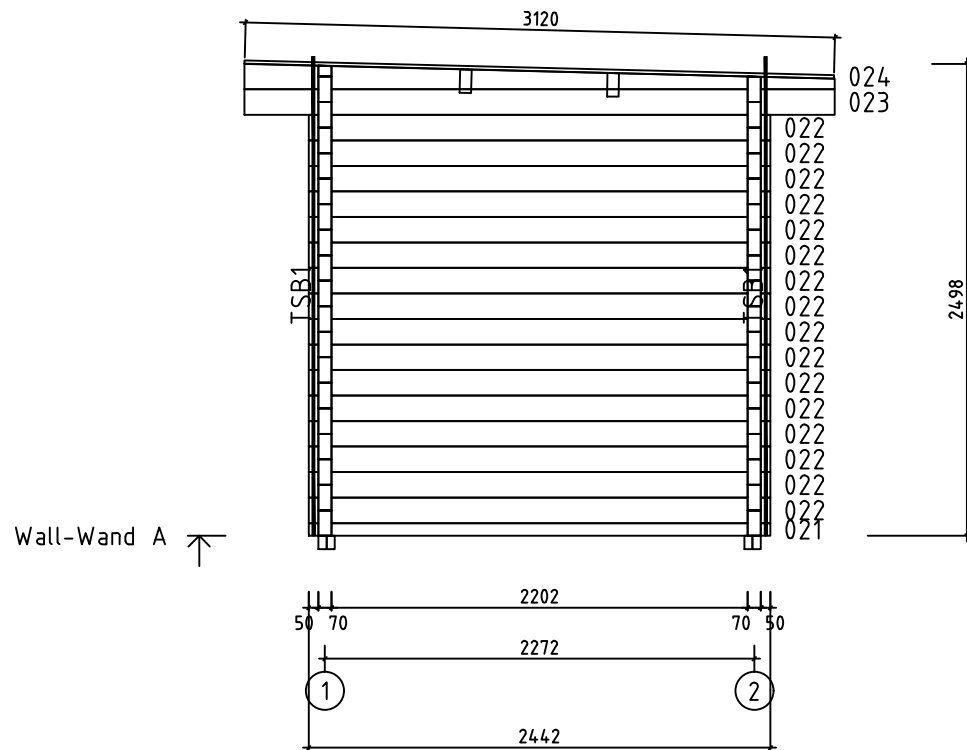

Model	Sauna Cubus 70 C	Drawing	WALL-WAND A	Page	2	
	Drawn by	R.T	Material	7x13.5	Scale	1:40
	Date	09.04.2024	File	Sauna Cubus 70 C.dwg		

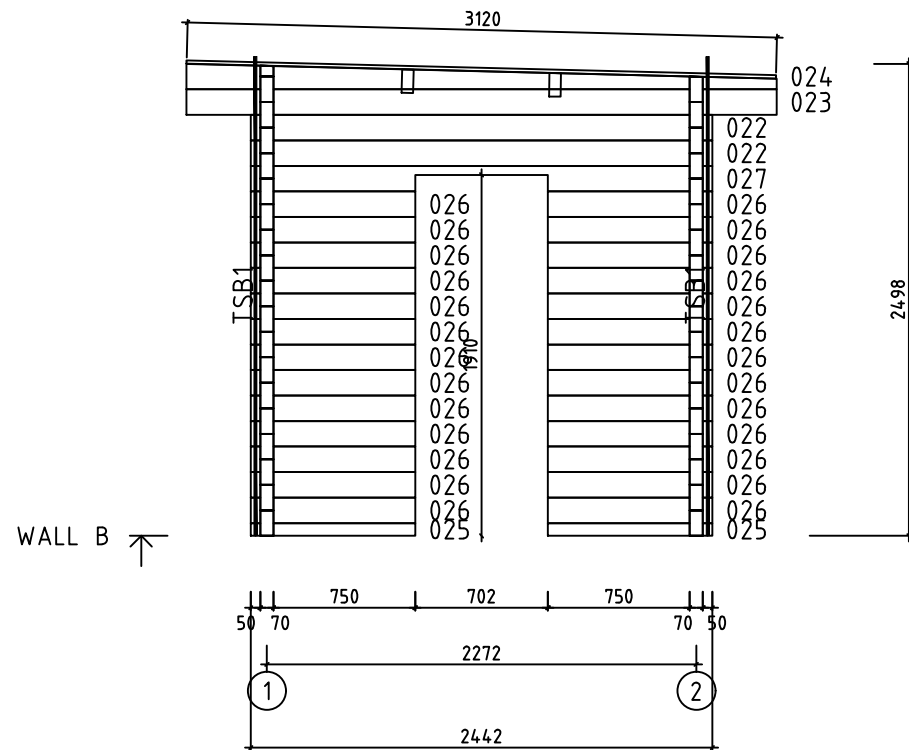

0 0.5m 1.0m 2.0m

Model	Sauna Cubus 70 C		Drawing	WALL B	Page	3
	Drawn by	R.T	Material	7x13.5	Scale	1:40
	Date	09.04.2024	File	Sauna Cubus 70 C.dwg		

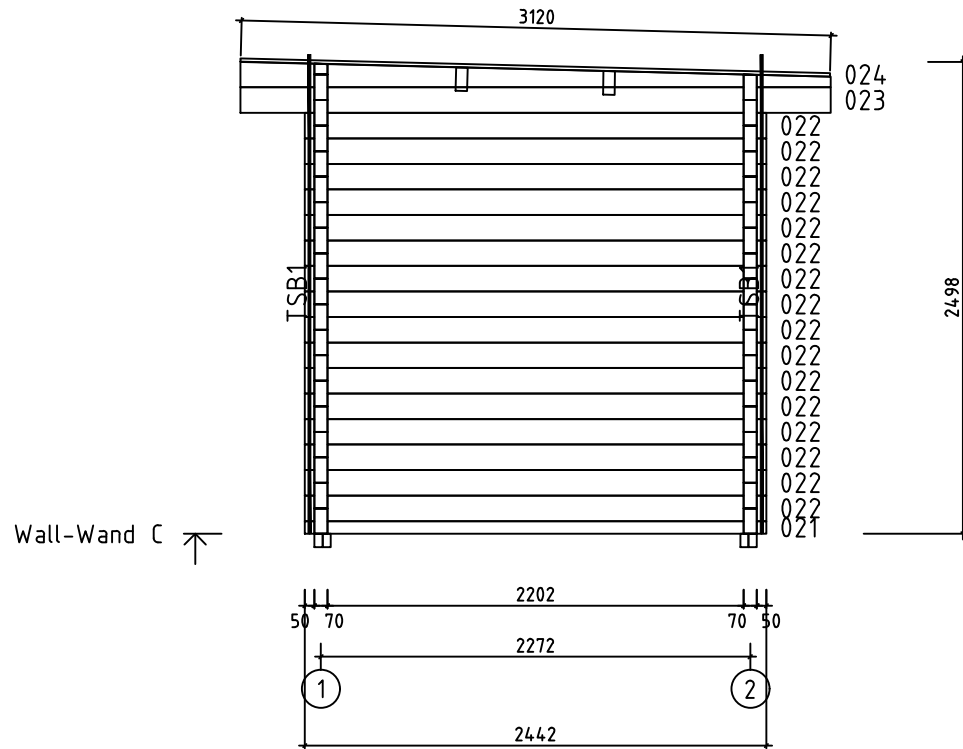

0 0,5m 1,0m 2,0m

Model	Sauna Cubus 70 C	Drawing	WALL-WAND C	Page	4	
	Drawn by	R.T	Material	7x13.5	Scale	1:40
	Date	09.04.2024	File	Sauna Cubus 70 C.dwg		

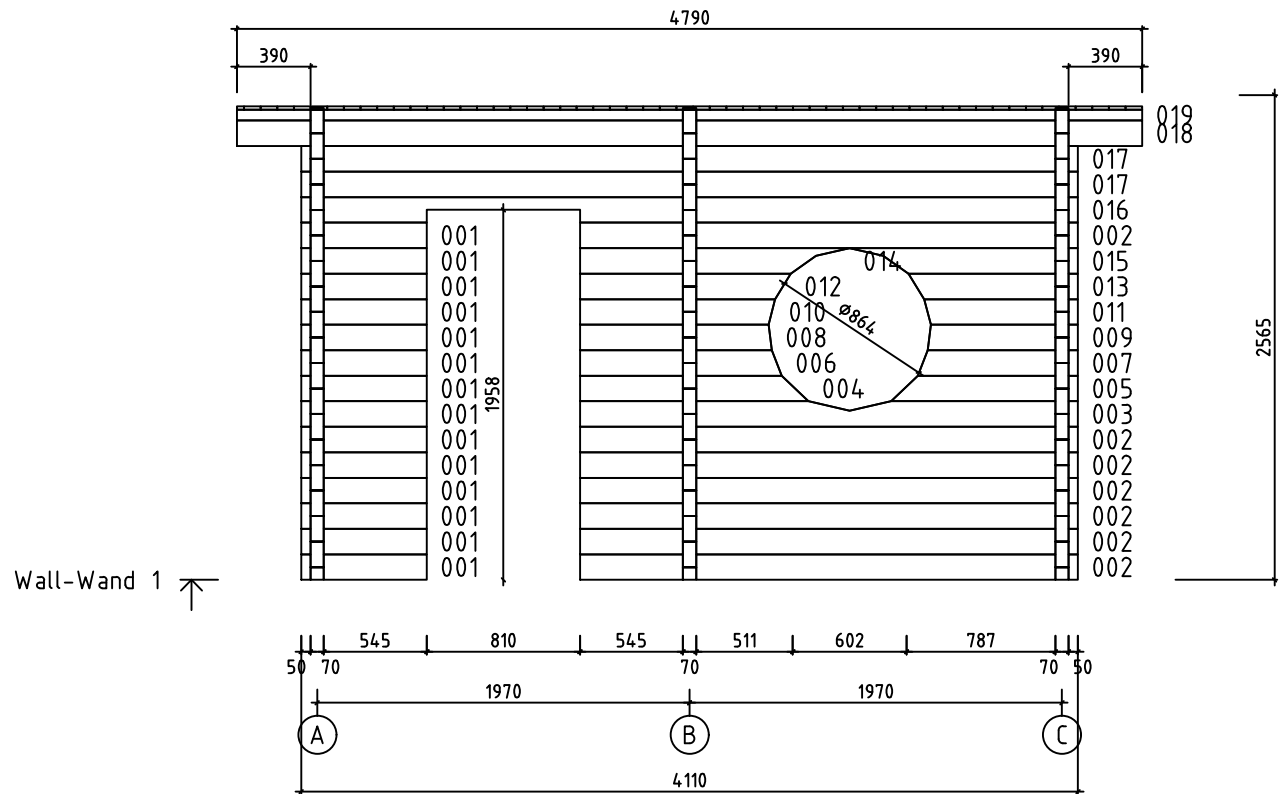

0 0,5m 1,0m 2,0m

Model	Sauna Cubus 70 C	Drawing	WALL-WAND 1	Page	5	
	Drawn by	R.T	Material	7x13.5	Scale	1:40
	Date	09.04.2024	File	Sauna Cubus 70 C.dwg		

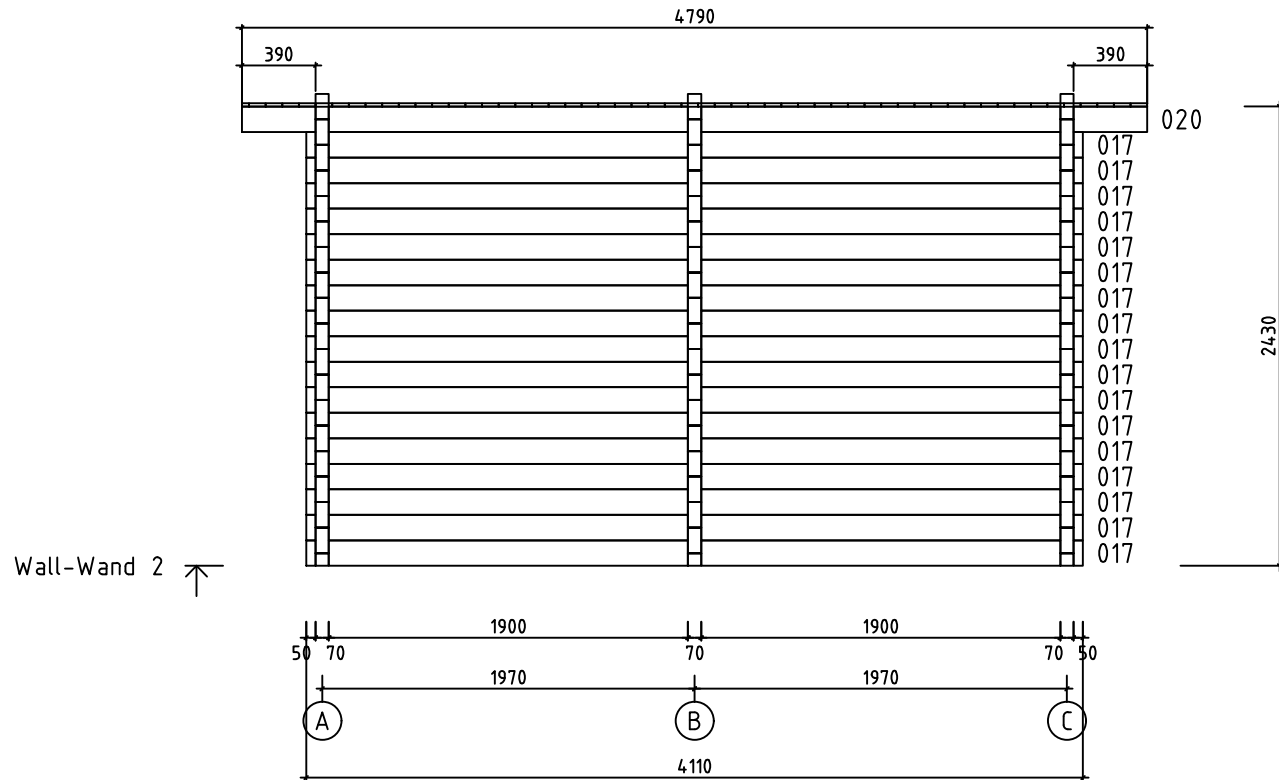

0 0,5m 1,0m 2,0m

Model	Sauna Cubus 70 C	Drawing	WALL-WAND 2	Page	6	
	Drawn by	R.T	Material	7x13.5	Scale	1:40
	Date	09.04.2024	File	Sauna Cubus 70 C.dwg		