

Alphol

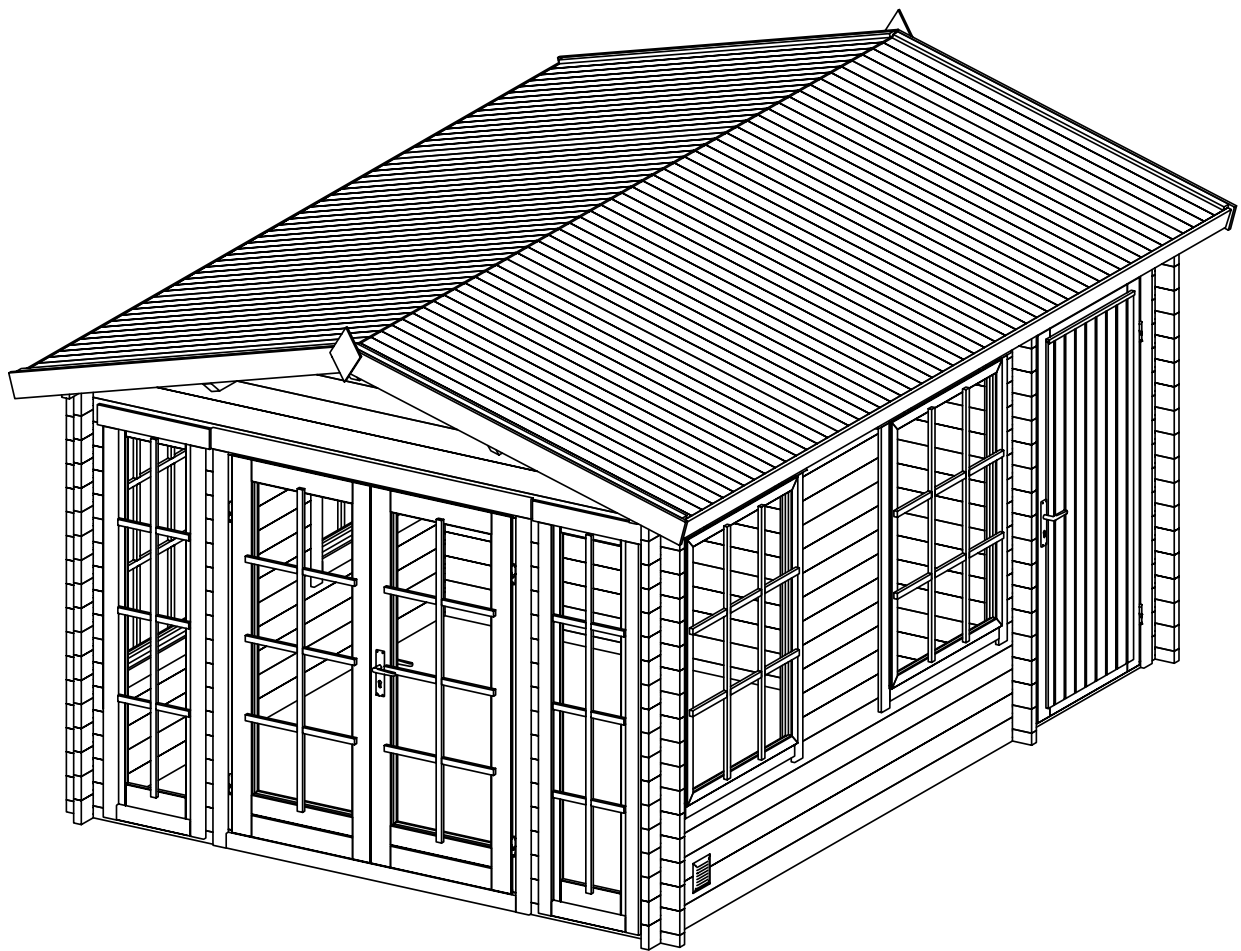

Kim 40

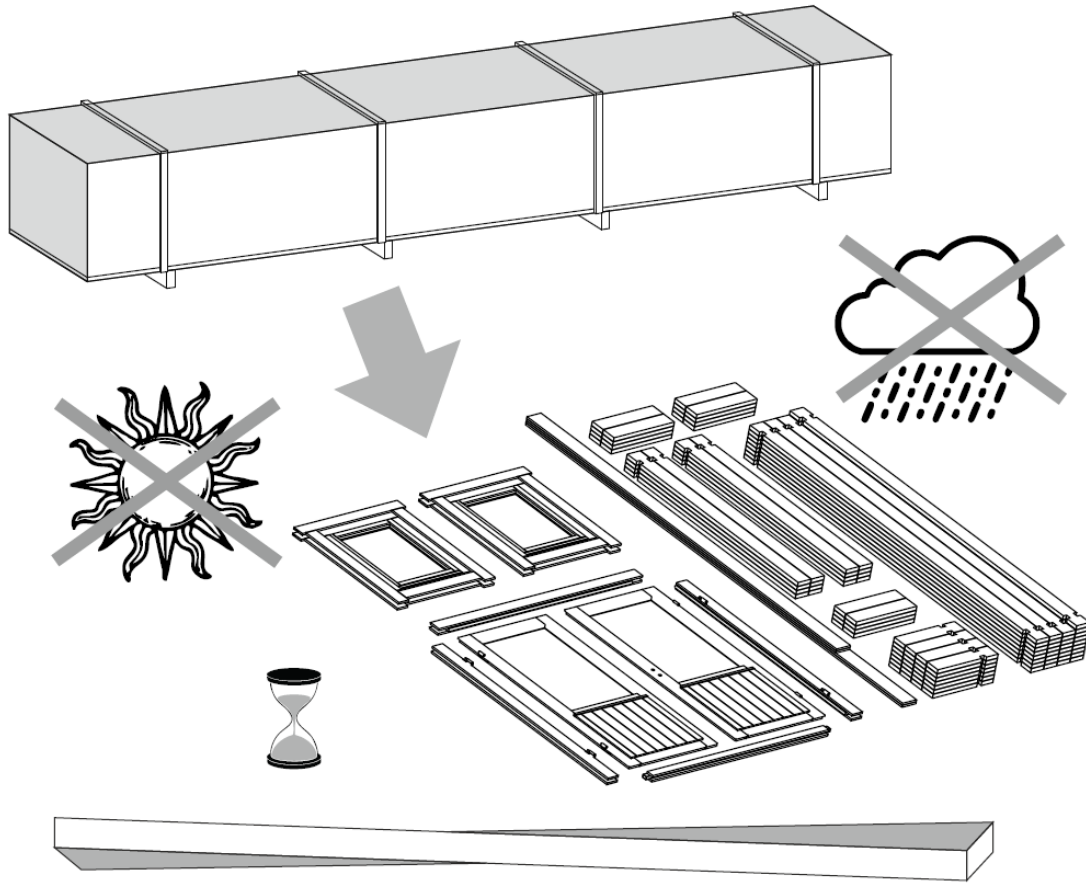

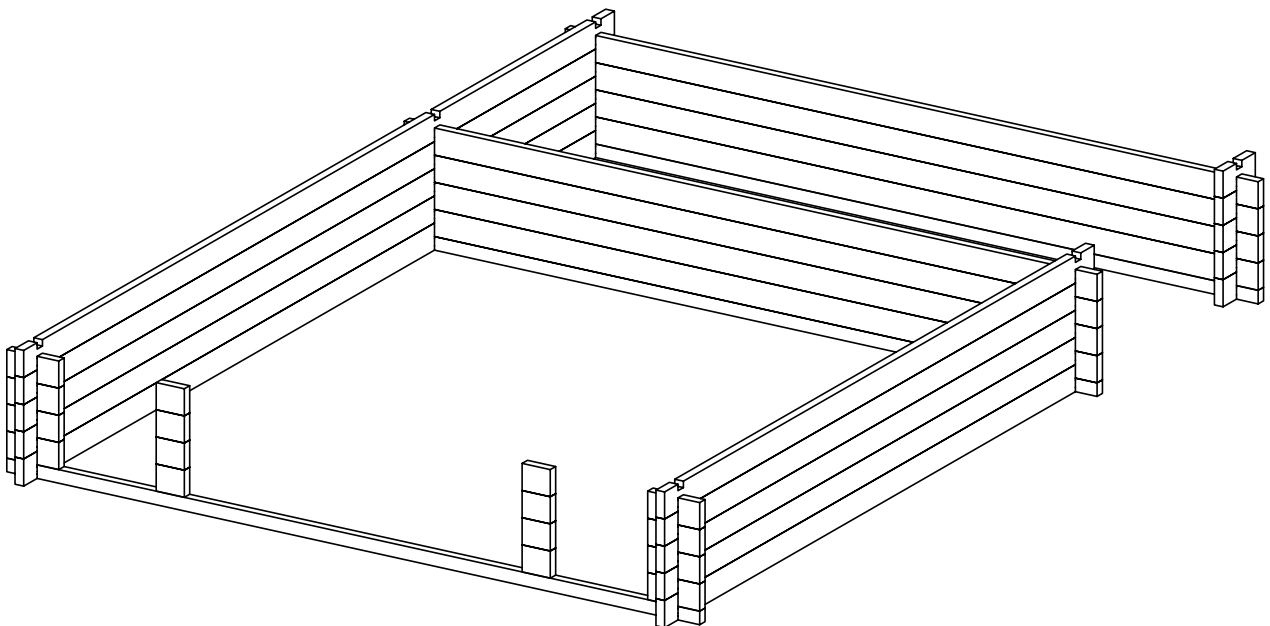
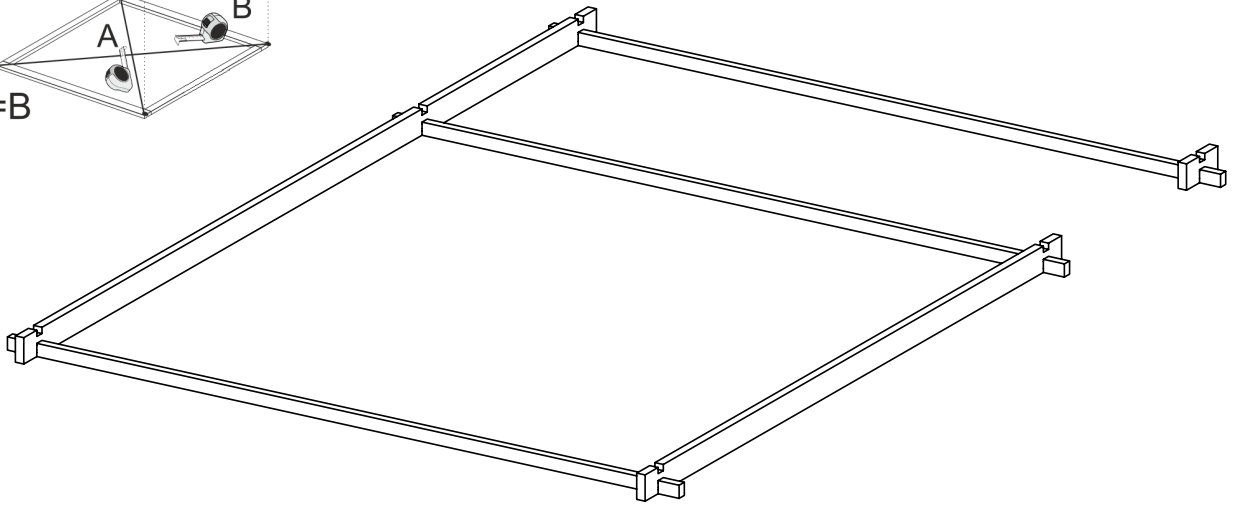
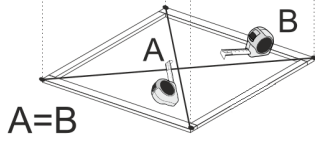
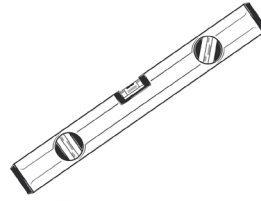
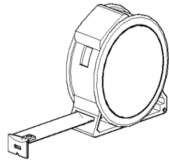
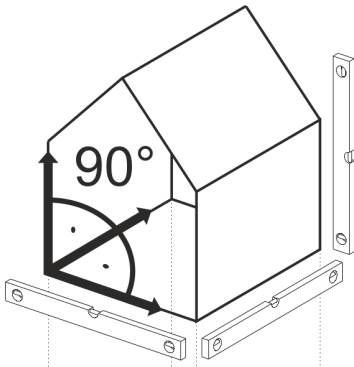

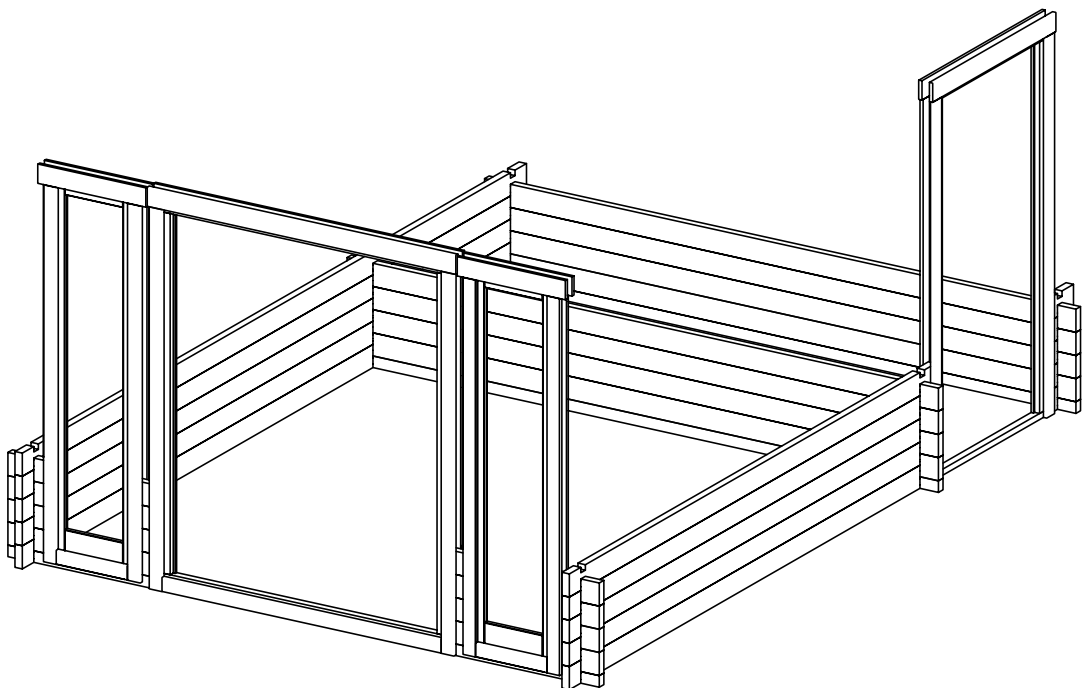
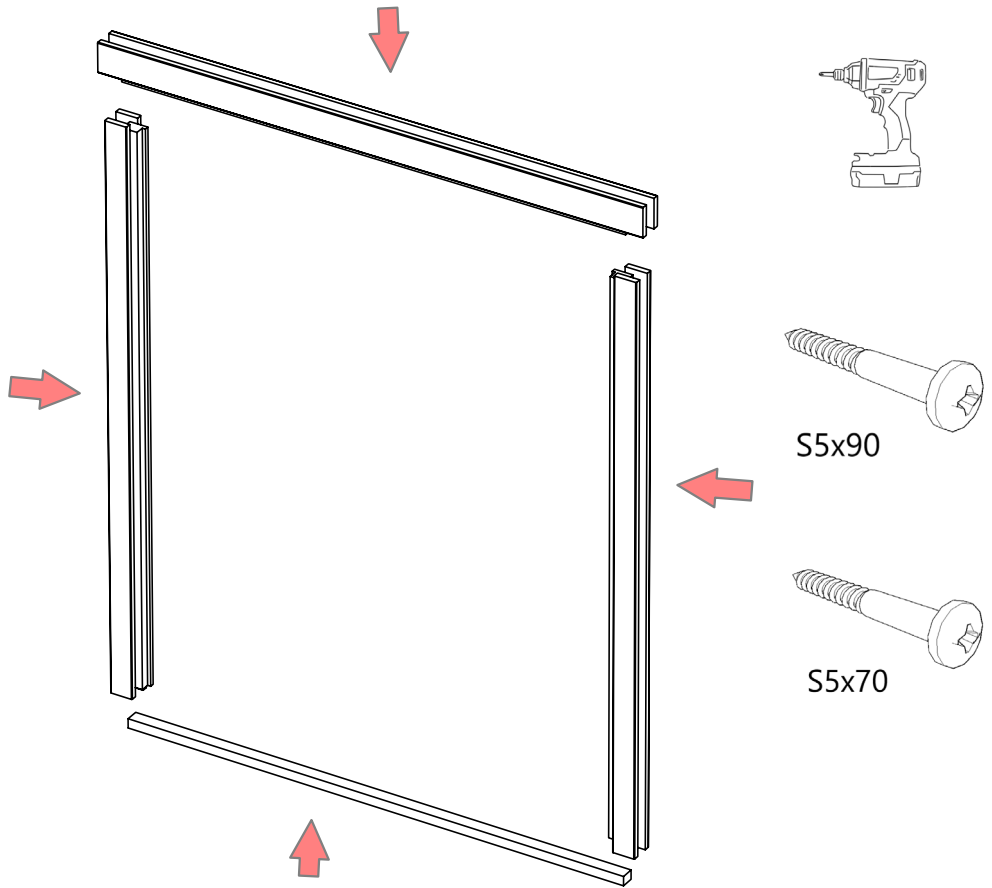

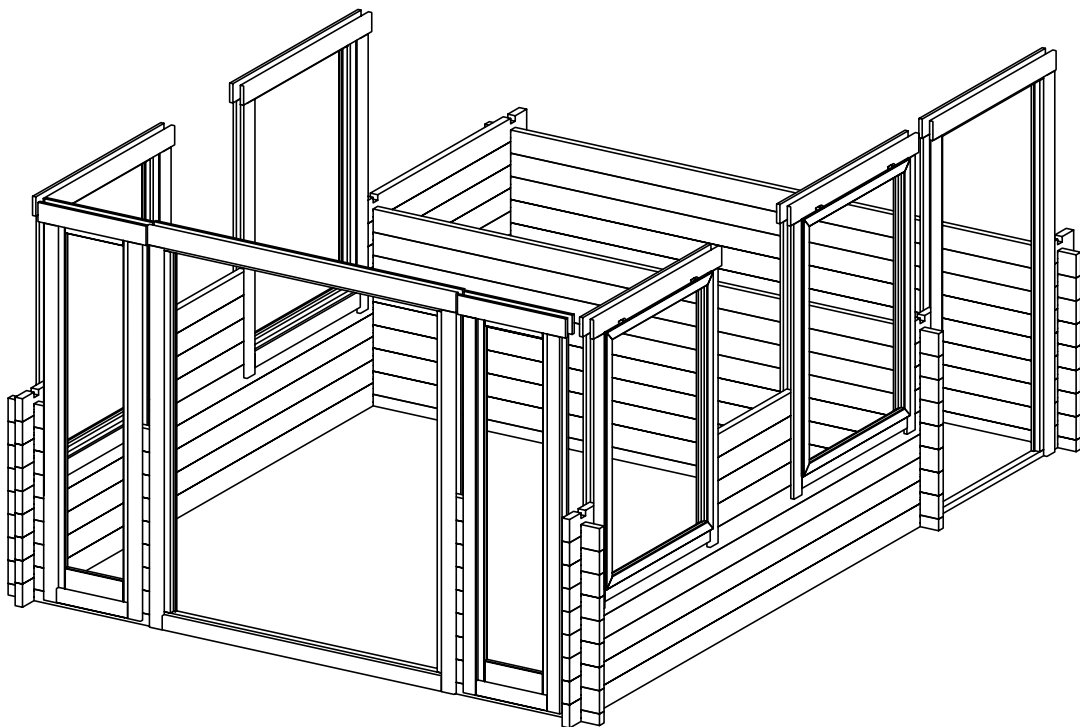
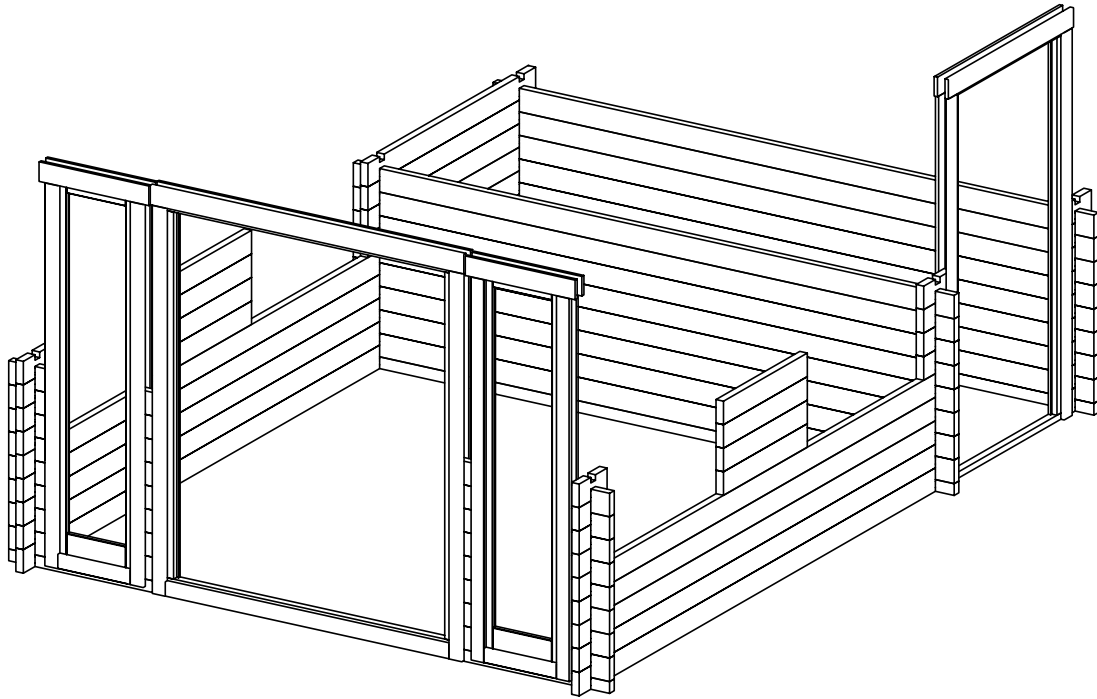

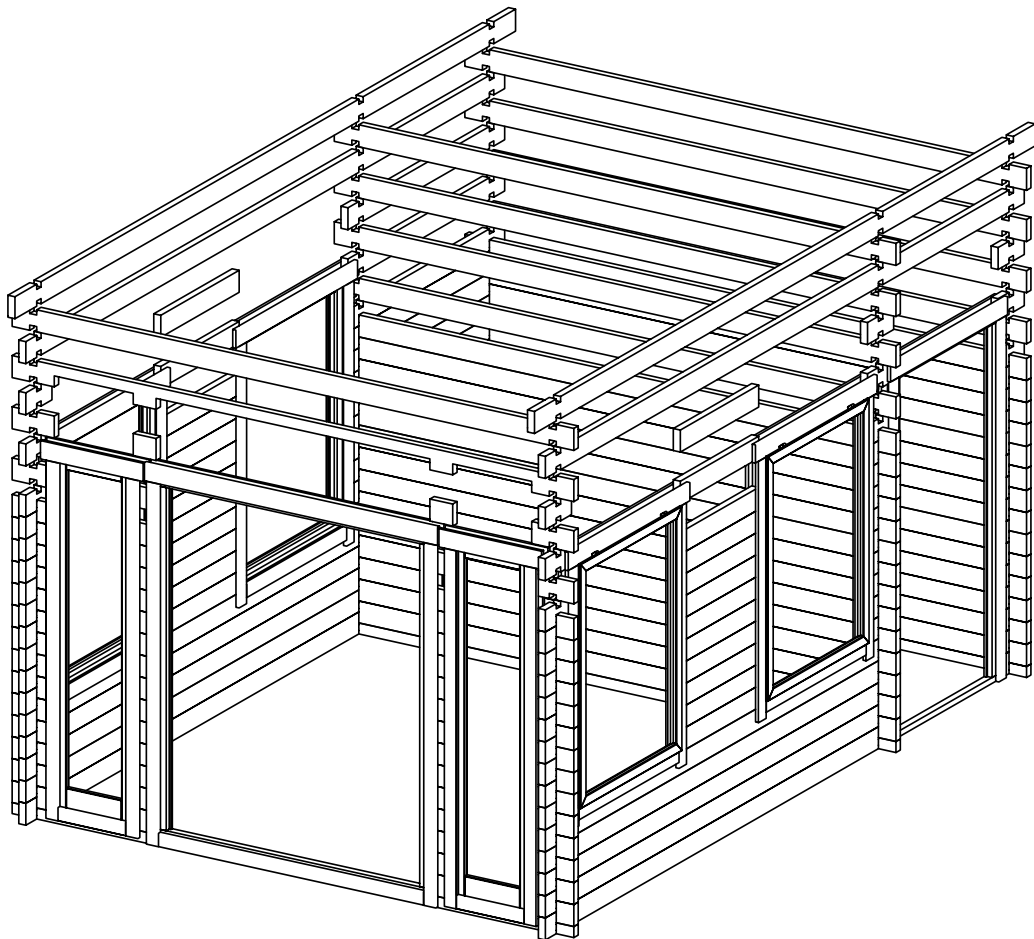
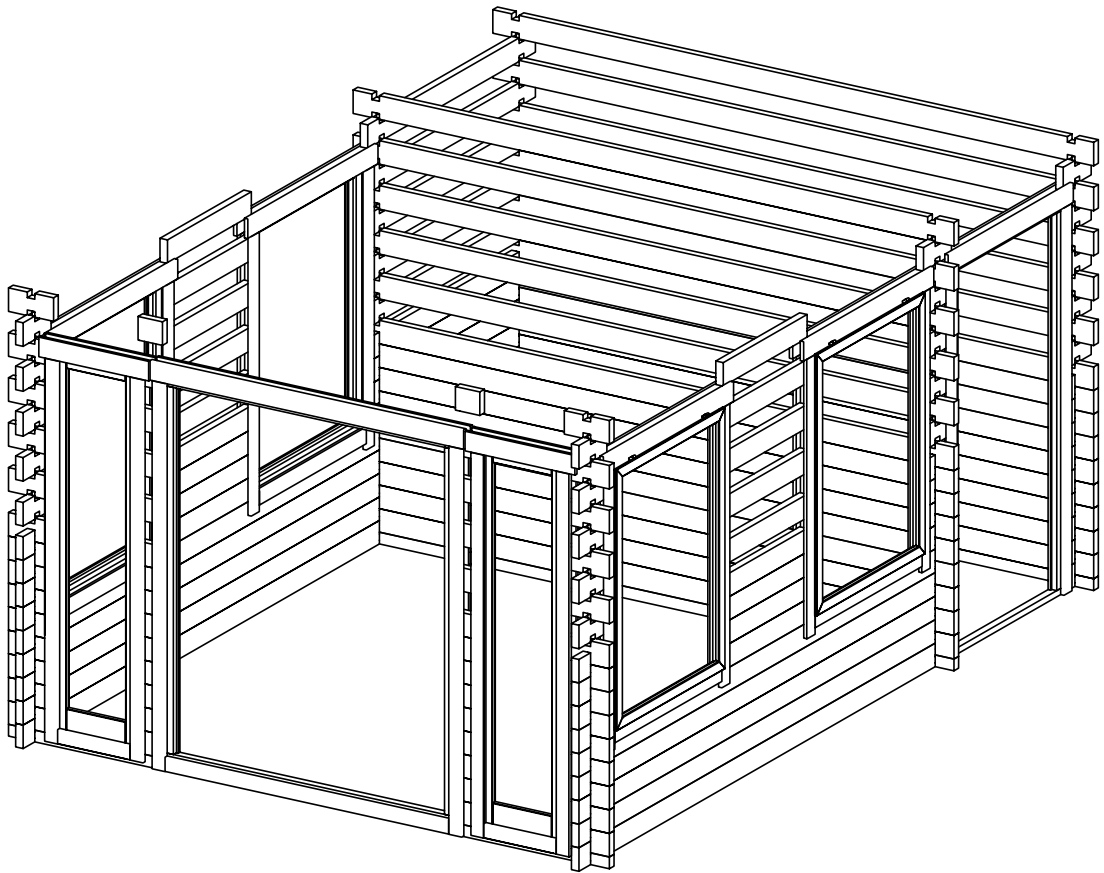

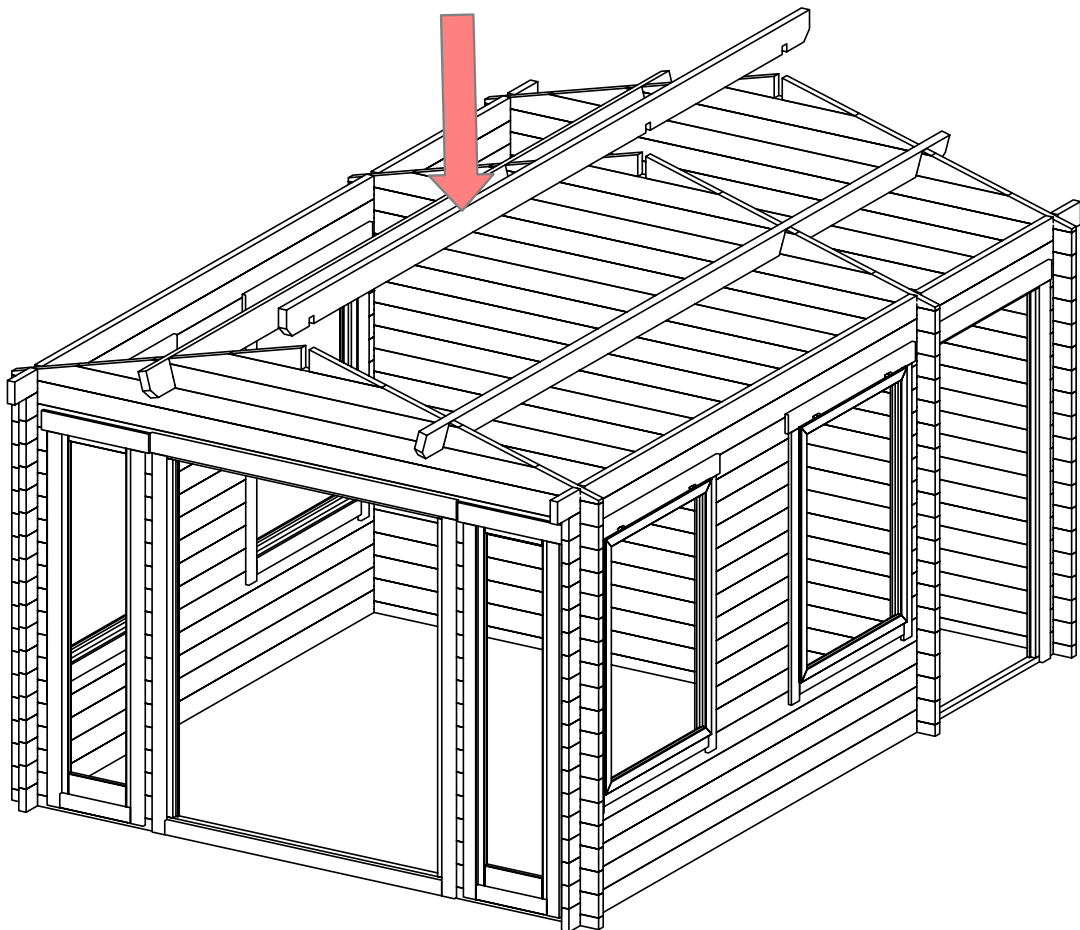
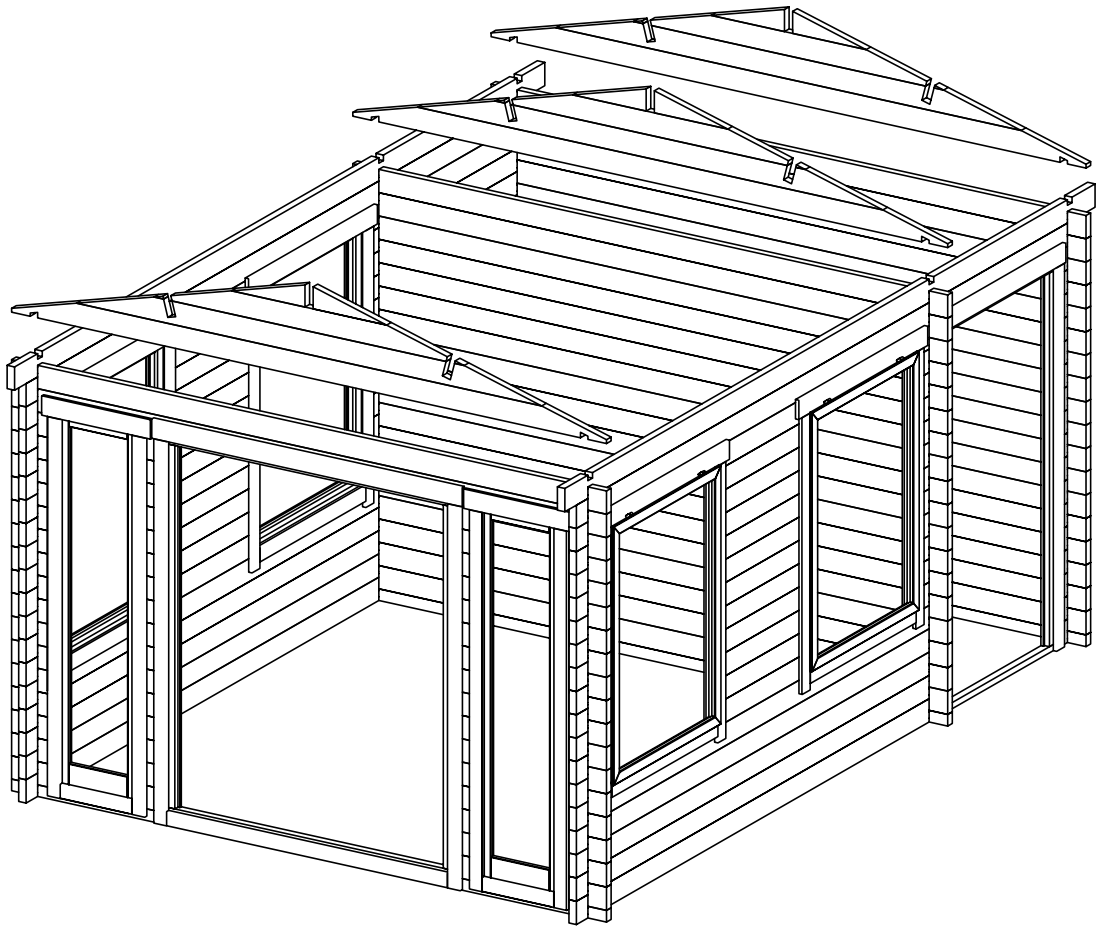

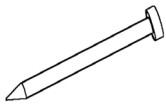
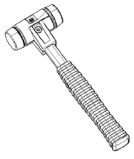

N1,8x40

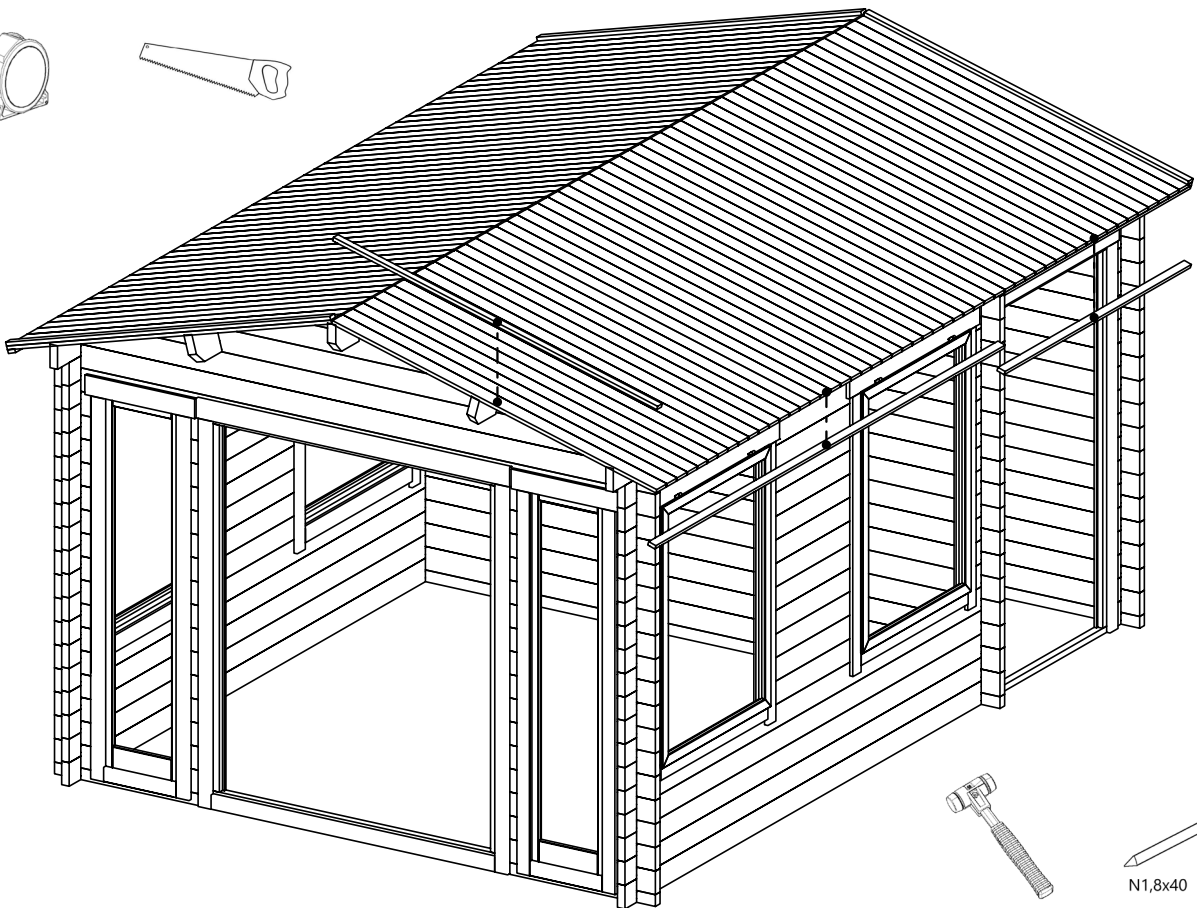
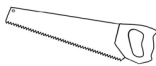
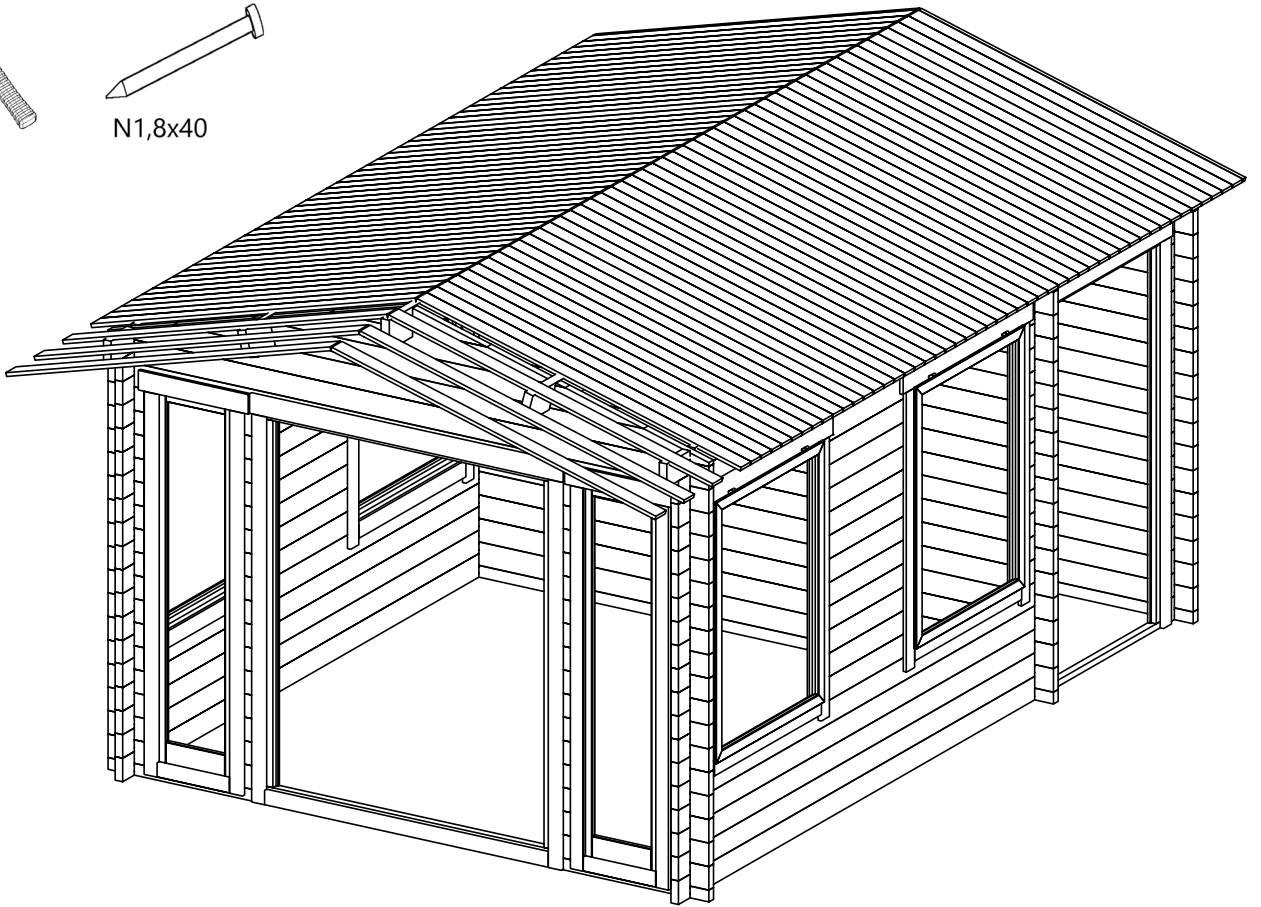

N1,8x40

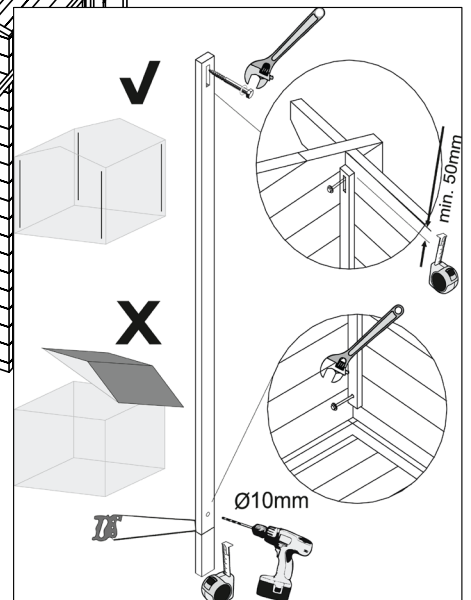
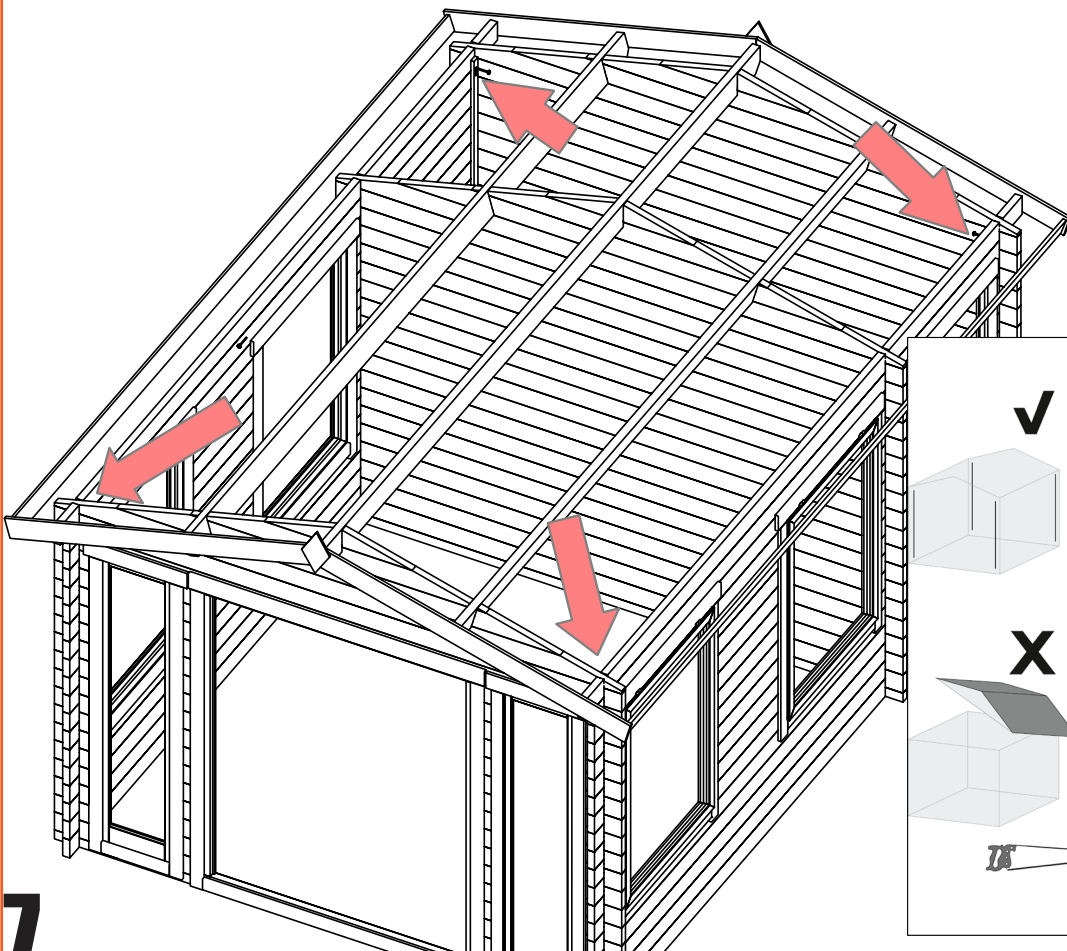
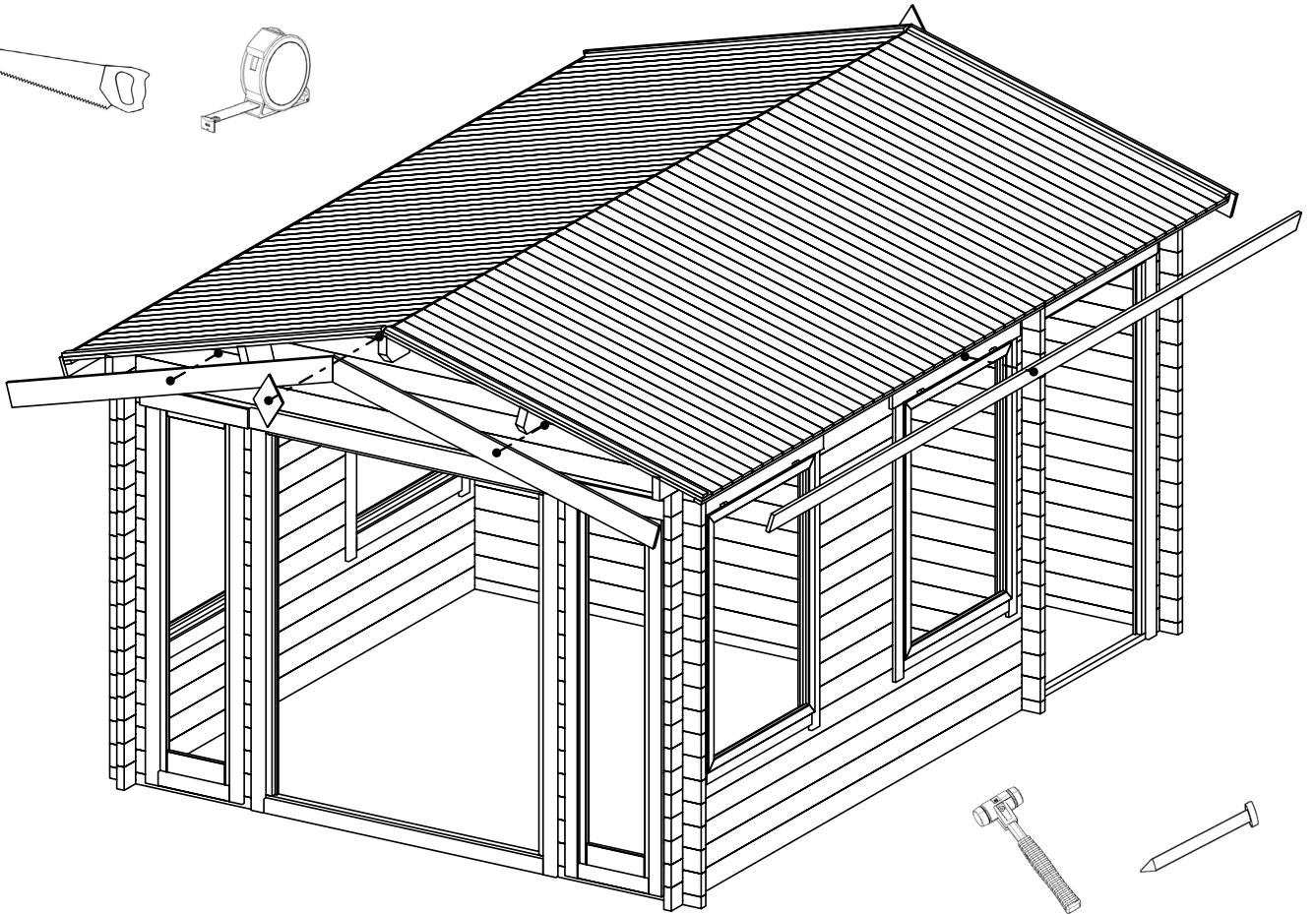
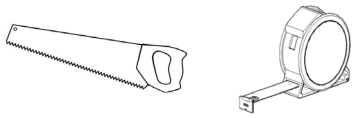

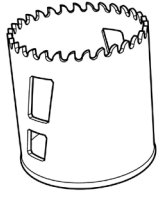
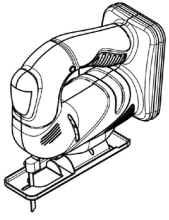



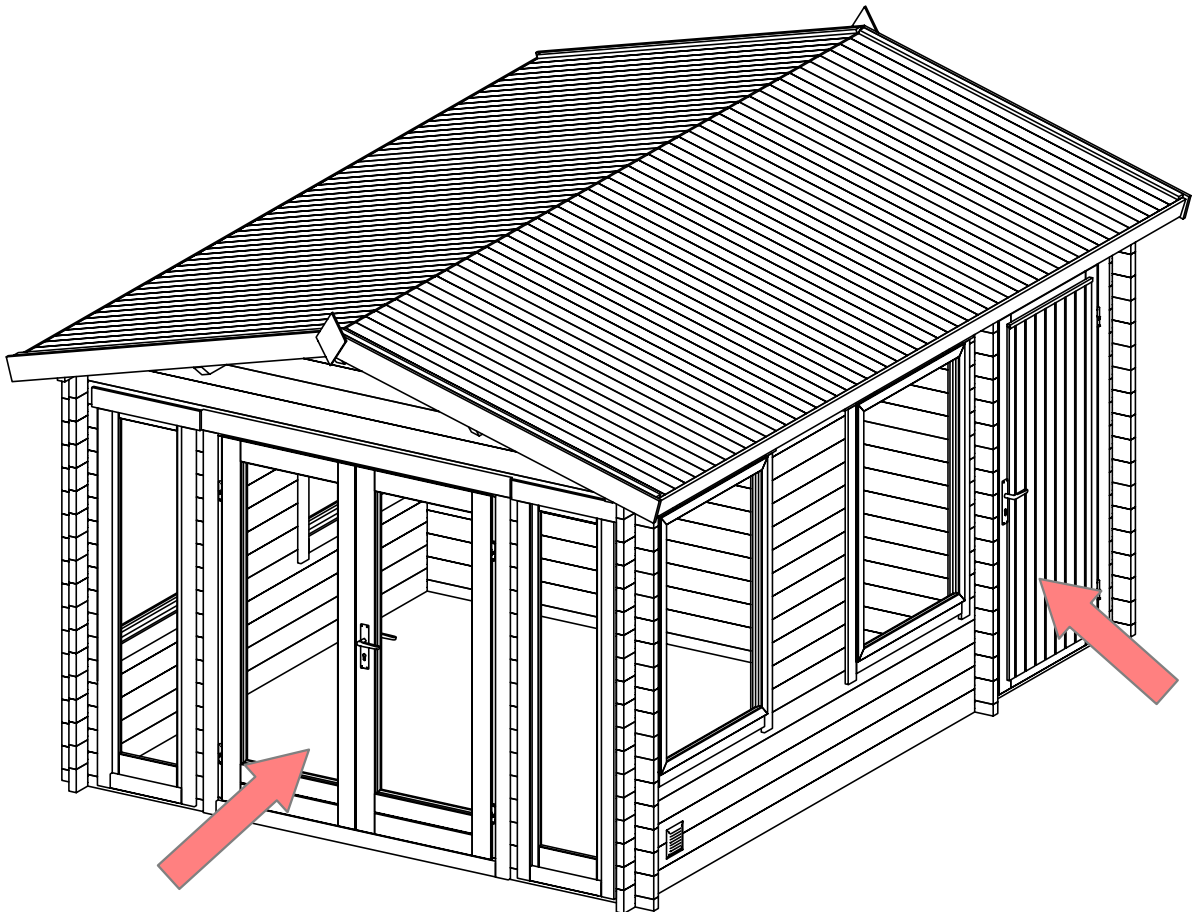
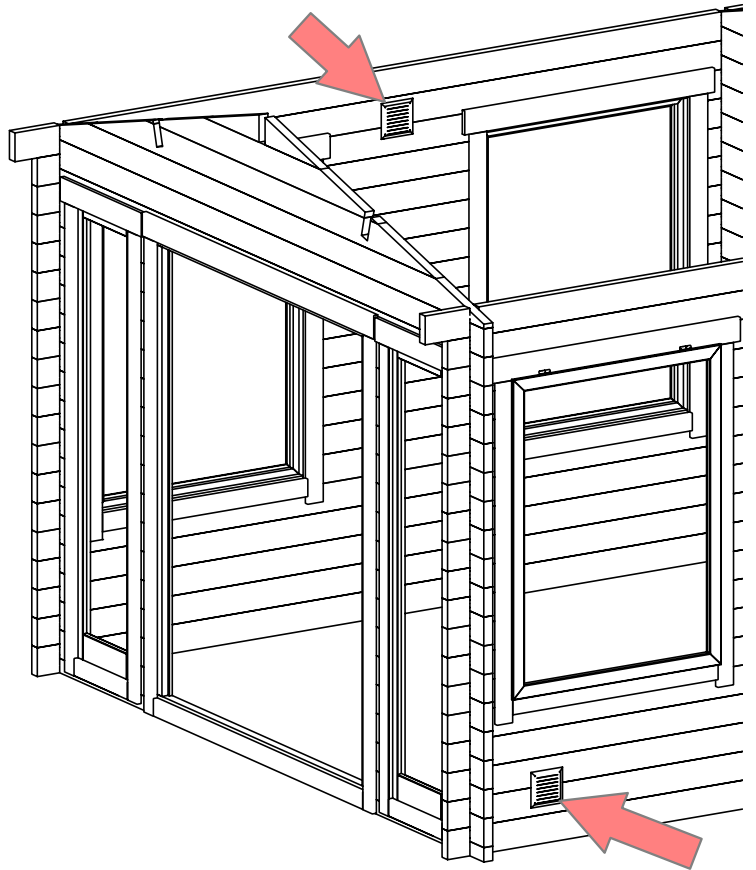
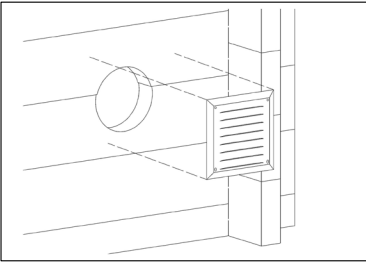
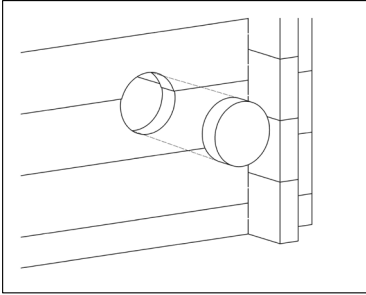

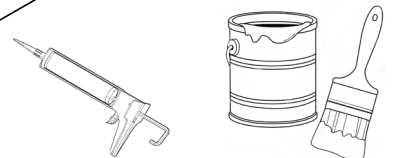
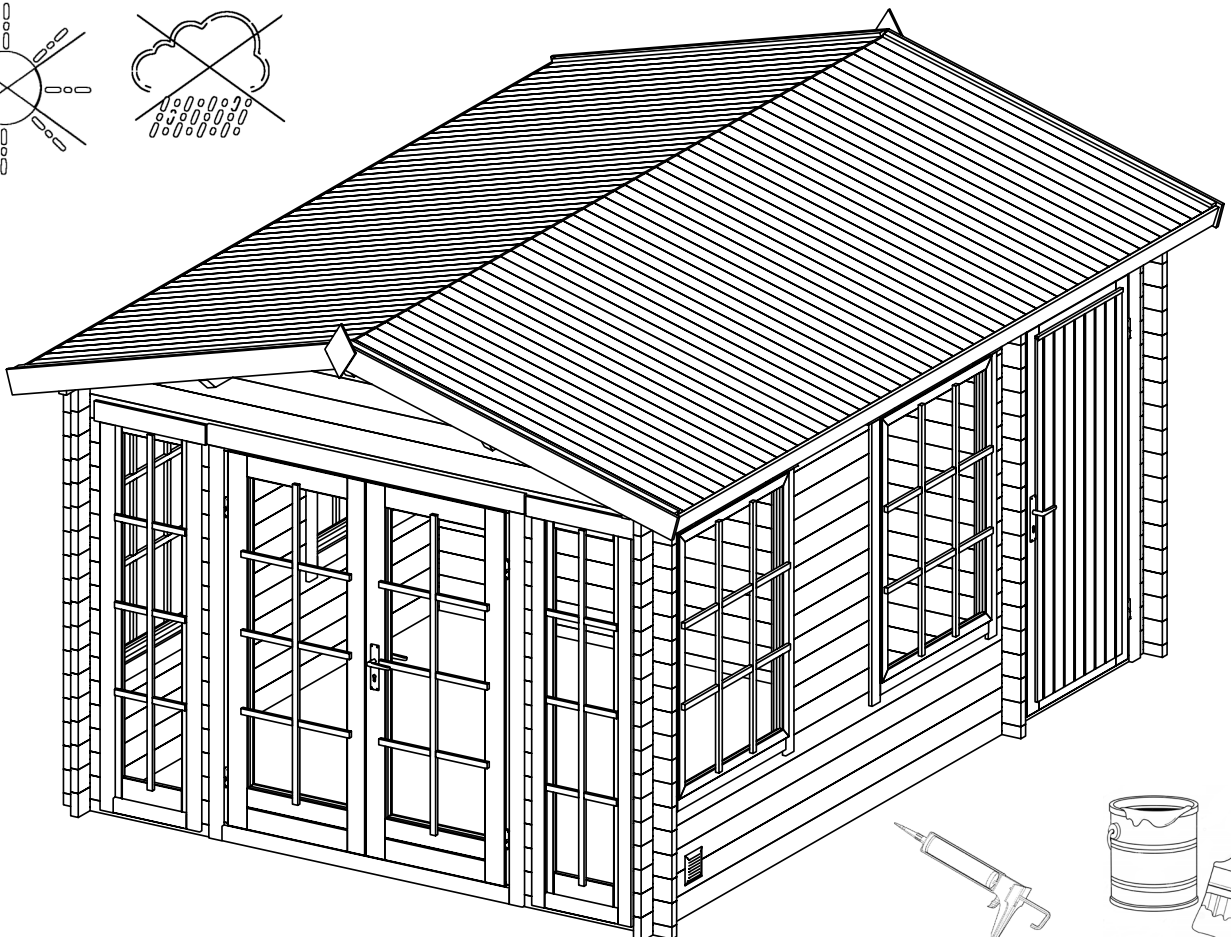
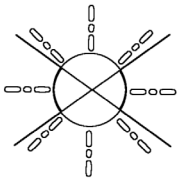
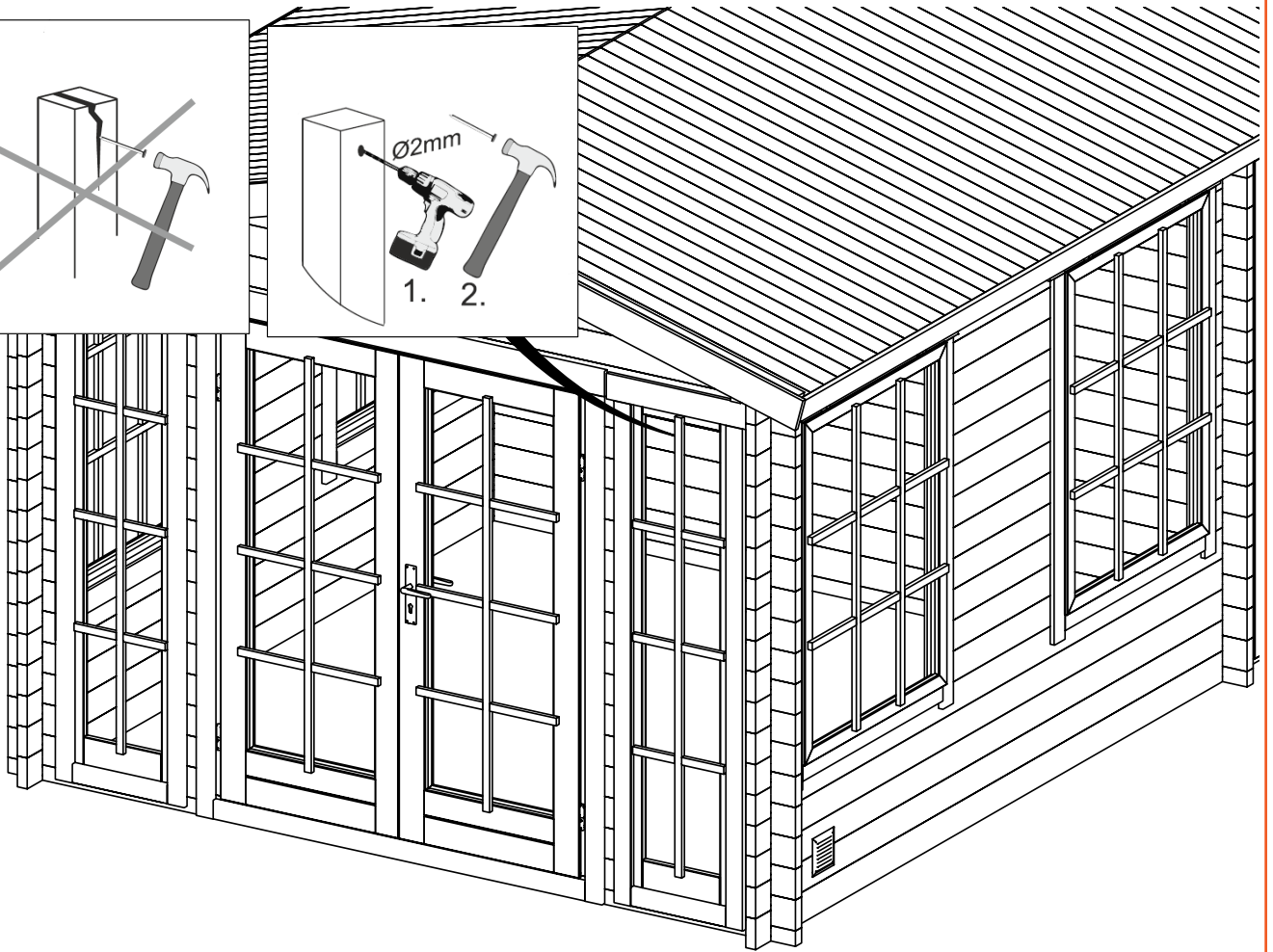
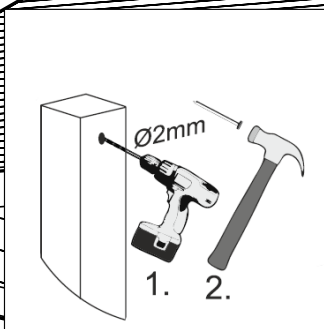
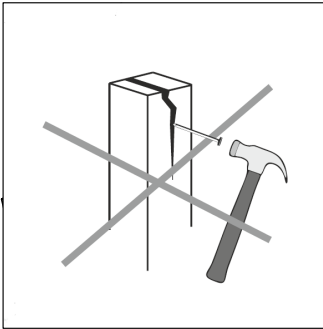

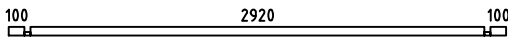

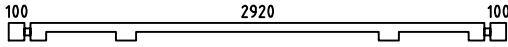
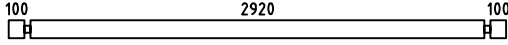
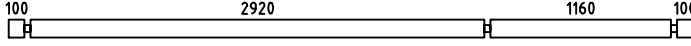
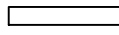
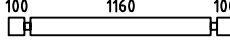
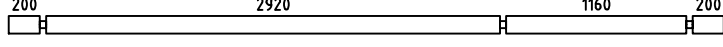
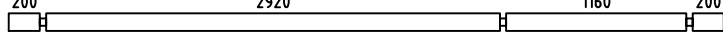
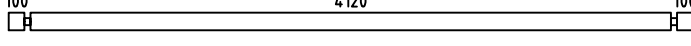
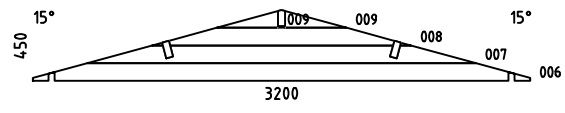
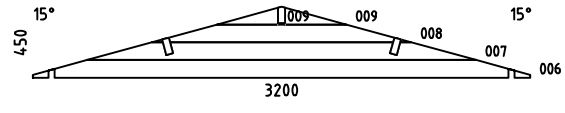
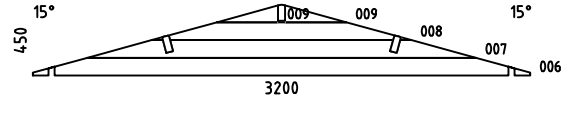
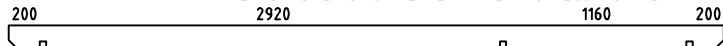
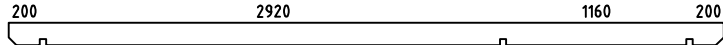

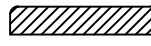

Ø ca 130mm

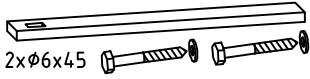

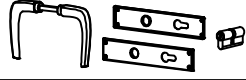

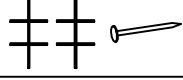

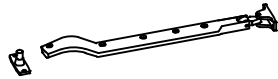
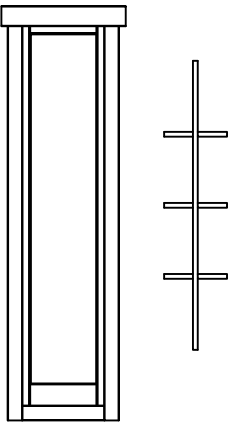
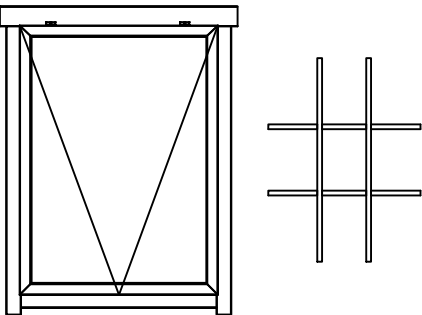
Pos	Specification-Spezifikation-Specificatie-Nomenclature-Elementi-Especificacion Kim 40	Qty	Profile (mm)	Lenght (mm)
001		3	40x57	3200
002		85	40x114	240
003		32	40x114	130
004		1	40x114	3200
005		42	40x114	3200
010		7	40x114	4400
011		24	40x114	720
012		12	40x114	1440
013		1	40x114	4600
014		1	40x114	4600
EXTRA		1	40x114	4400
W1-1		1		
W2-1		1		
W3-1		1		
PL1		2	44x144	4600
PL2		1	44x144	4600
R-1	Roof board-Dachbrett-Dakplank-Volige-Tavola tetto-Tabla de tejado 	106+1 81+1	88x18 114x18	1790
GB-1	Gable board 95-Giebelblende-Gevelplank-Planche de rive-Tavola di bordo-Tabla de borde 	2	18x95	4600
GB-1	Gable board 120-Giebelblende-Gevelplank-Planche de rive-Tavola di bordo-Tabla de borde 	4	18x120	1830
RL-1	Roofing lath 3000-Giebelleiste-Gevellijst-Latte de rive>Listello di bordo>Listones de borde 	6	18x40	18 rmt
Model	Kim 40	Material	Page 1/3	

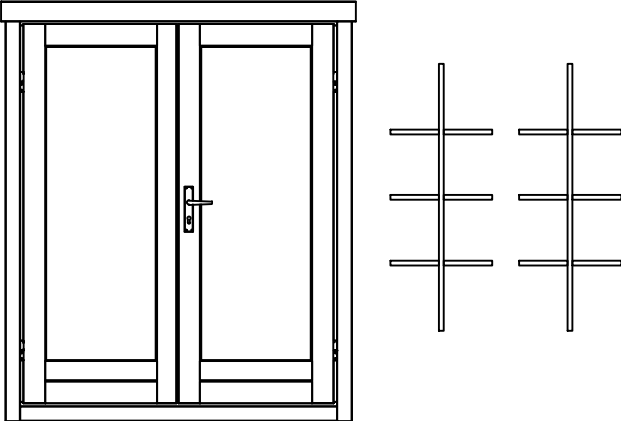
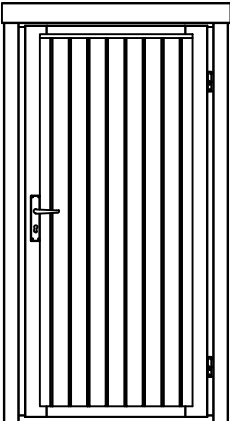
Pos	Specification-Spezifikation-Specificatie-Nomenclature-Elementi-Especificacion Kim 40	Qty	Profile (mm)	Lenght (mm)
SS-1	Storm slat kit-Sturmleiste satz-Stormanker set-Kit de latte anti tempête-Kit listello di tempesta-Kit liston anti tormenta 	4	18x40	2000
D	Diamond 	2		
	Door kit-Tür satz-Deur set-Kit porte-Kit porta-Kit para puerta 	1		
	Double door kit-Doppeltür satz-Dubbele deur set-Kit double porte-Kit porta-Kit para puerta 	1		
	Nail 1.6x30-Nagel-Spijker-Clou-Chiodo-Clavo 	65	1.6x30	
	Nail 1.8x40-Nagel-Spijker-Clou-Chiodo-Clavo 	350	1.8x40	
	Ventilation panel kit-Außengitter-Schoepenrooster-Panneau de ventilation-Griglia di ventilazione-Rejilla de ventilacion 	1		
	Window stay-Fensterfeststeller-Raamuitzetter-Limiteur d'ouverture fenêtre-Vento bretelle-Soporte de ventana 	4		
	WINDOW 445x1850 W0-8 H 445x1850-40 	2		
	WINDOW 990x1325 W0-9N 990x1325-40 	4		
Model	Kim 40	Material	Page	2/3

Pos	Specification-Spezifikation-Specificatie-Nomenclature-Elementi-Especificacion Kim 40	Qty	Profile (mm)	Lenght (mm)
	<p data-bbox="635 152 887 203">DOOR 1540x1850 DD08-8 H 1540x1850-40</p> 	1		
	<p data-bbox="644 680 877 732">DOOR 945x1900 SDL F 945x1900-40 R</p> 	1		
Model	Kim 40	Material	Page	3/3

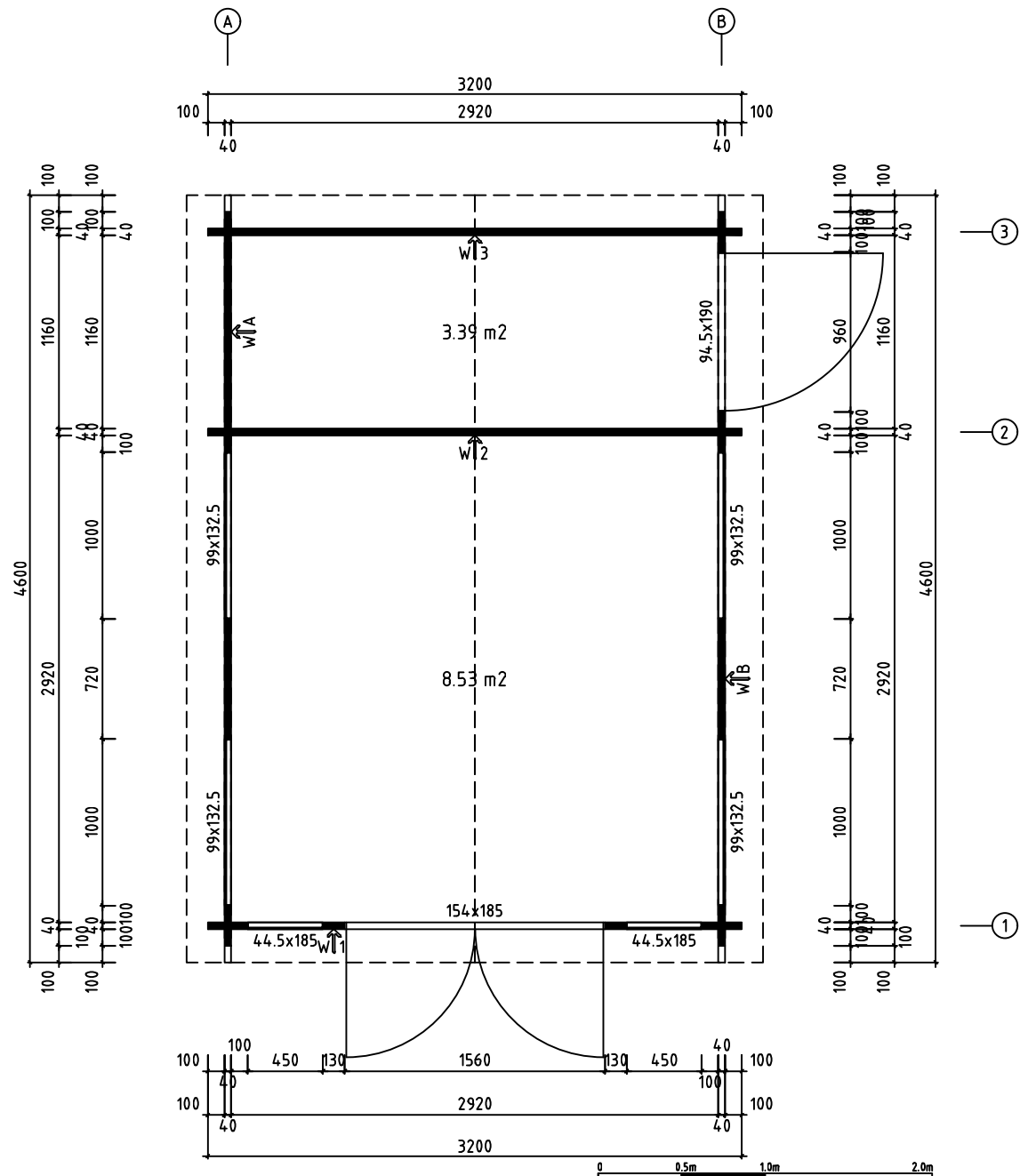
H = 1.400 m
 TOTAL: 11.91 m²



Model	Kim 40	Drawing	PLAN	Page	4x11.4
		Drawn by	2	Material	17.05.2023
		Date	Kim 40.dwg	File	J.S
			Scale	1:30	

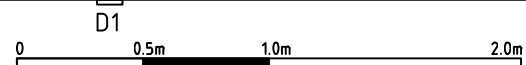
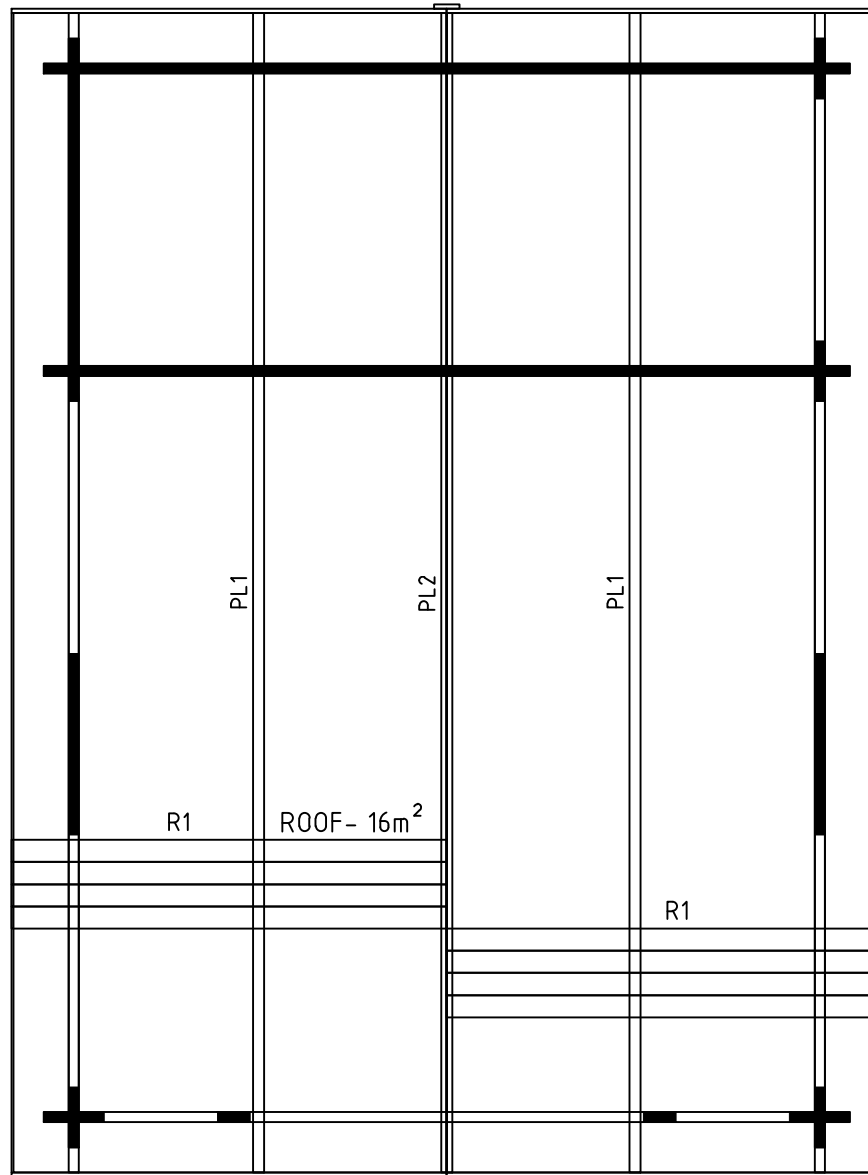

Model	Kim 40	Drawing	ROOF	Page
	Drawn by	J.S	Material	40x114
	Date	17.05.2023	File	Kim 40.dwg
			Scale	1:30

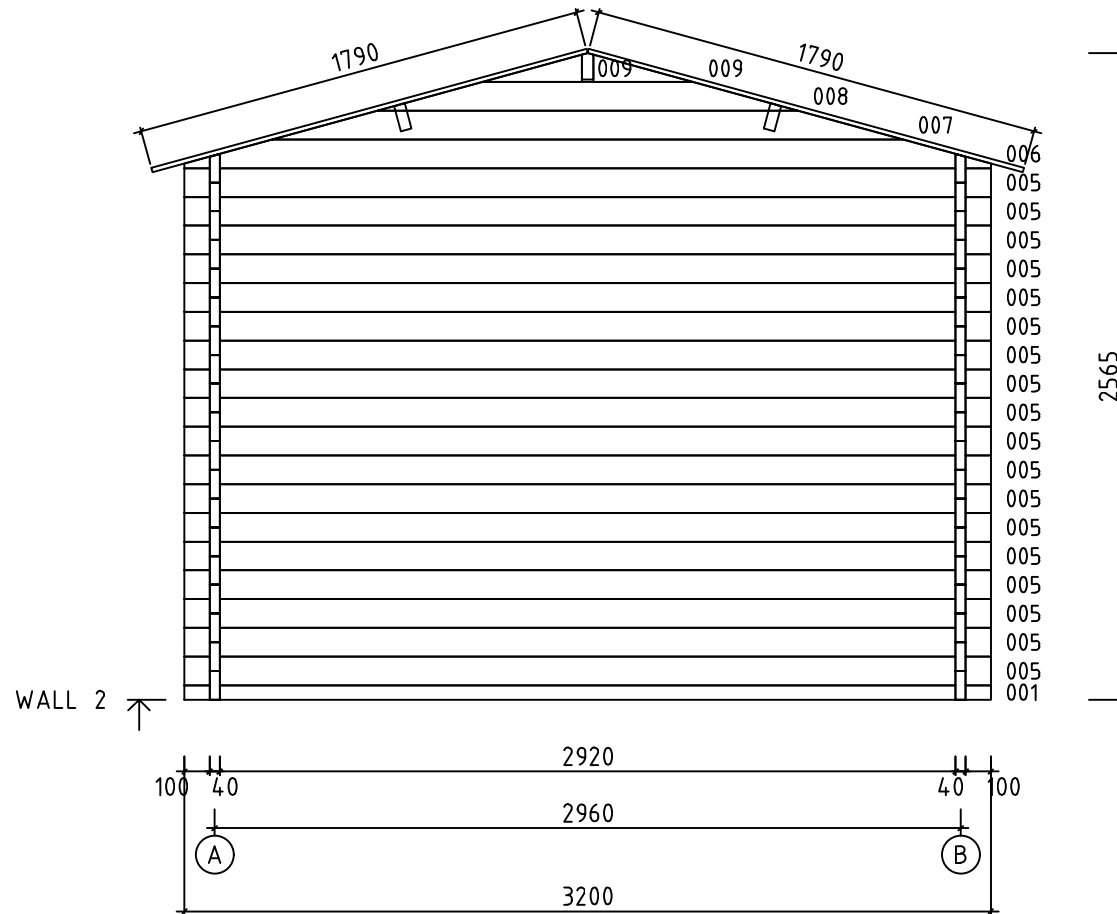

0 0.5m 1.0m 2.0m

Model	Kim 40	Drawing	WALL 2	Page	6	
	Drawn by	J.S	Material	4 x 11.4	Scale	1:30
	Date	17.05.2023	File	Kim 40.dwg		

