

# SAUNA L113 x 271

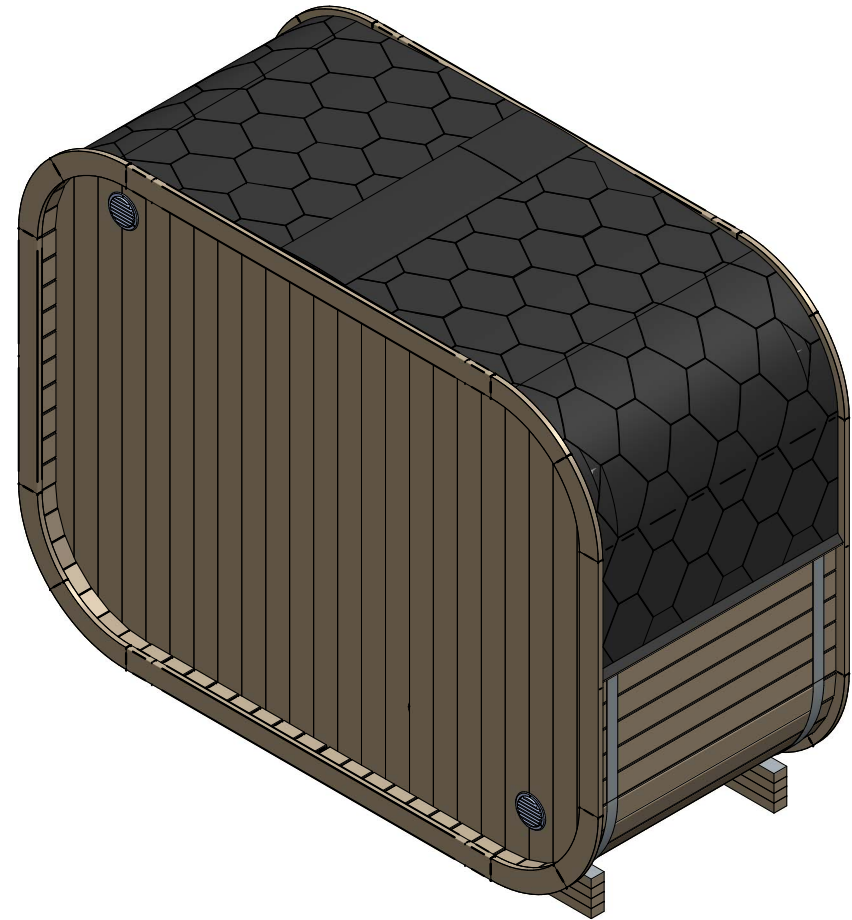
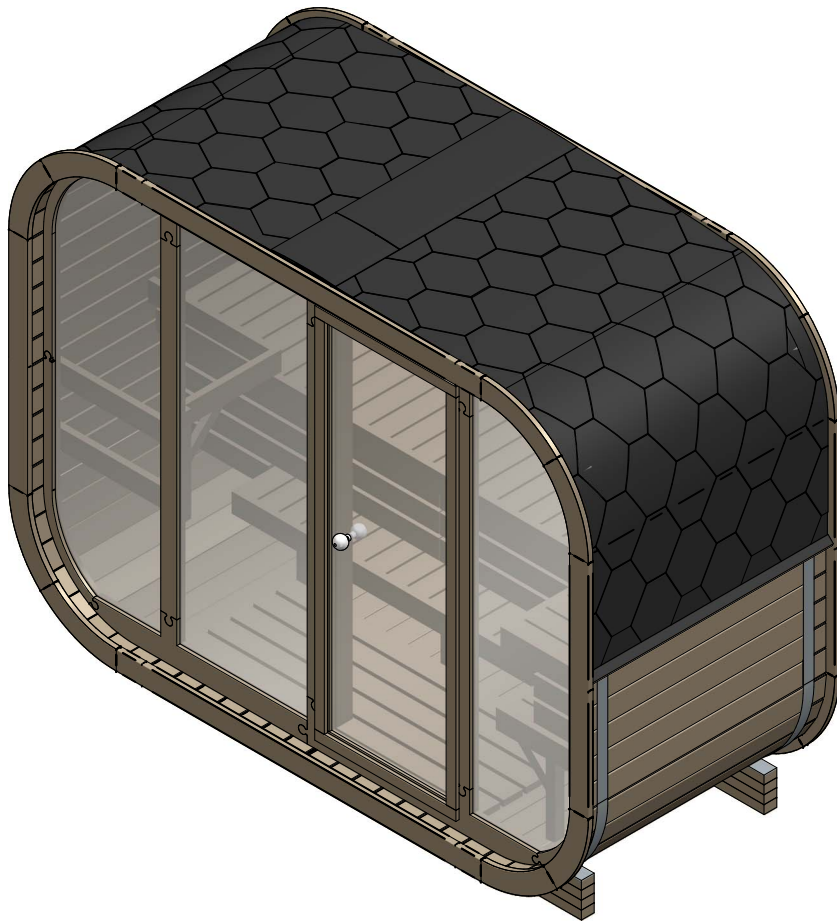

Before you start assembling the sauna, please read the entire manual.  
All units of measurement are in millimeters.  
A sauna barrel can never be 100% tight due to the construction.

Bevor Sie mit der Saunamontage beginnen, lesen Sie bitte die ganze Anleitung durch.  
Alle Maßeinheiten sind in Millimeter angegeben.  
Ein Saunafass kann durch die Bauweise nie zu 100% dicht sein.

Serial no. : \_\_\_\_\_

Tools that make your construction easier.

Not included in the delivery.





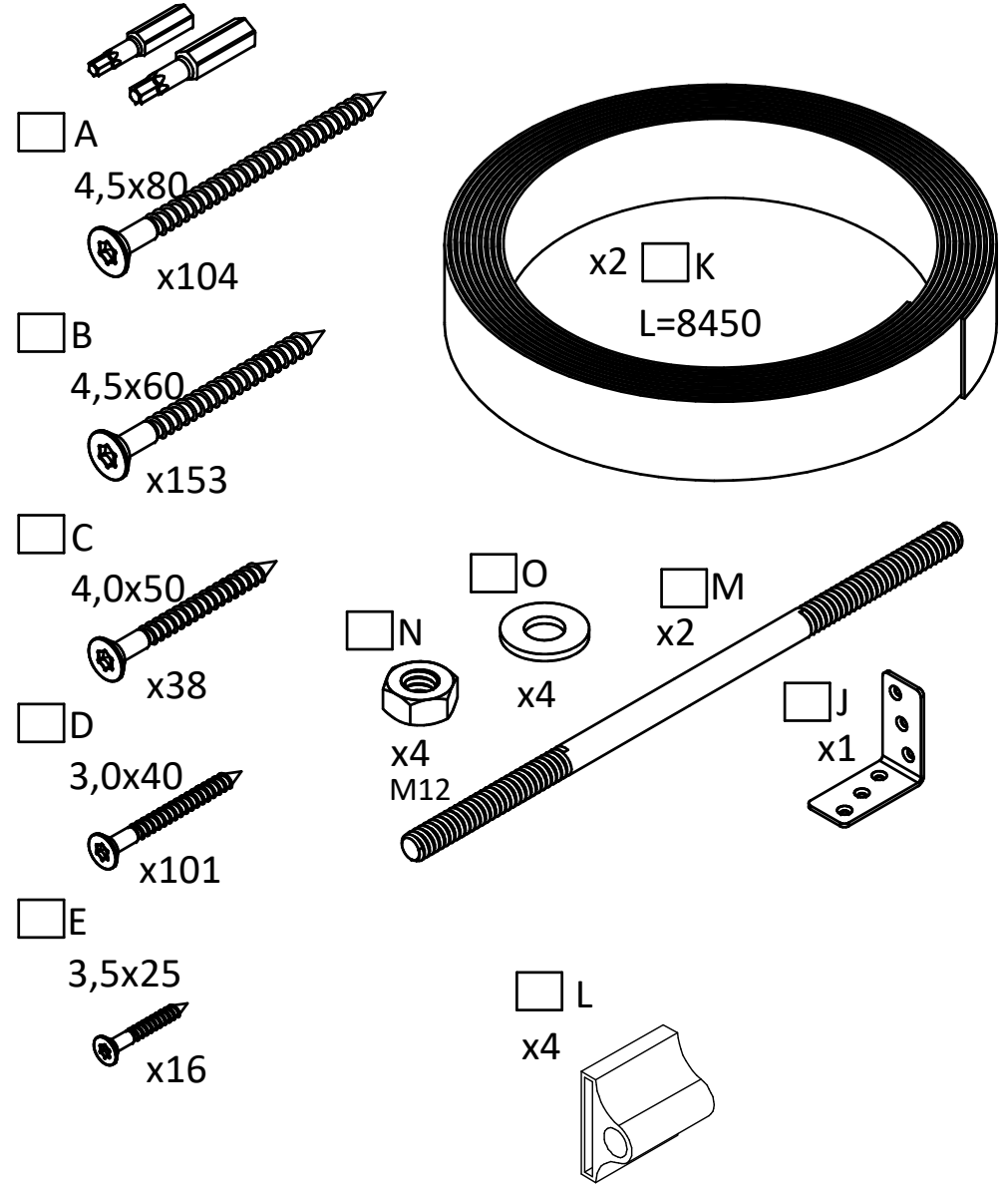
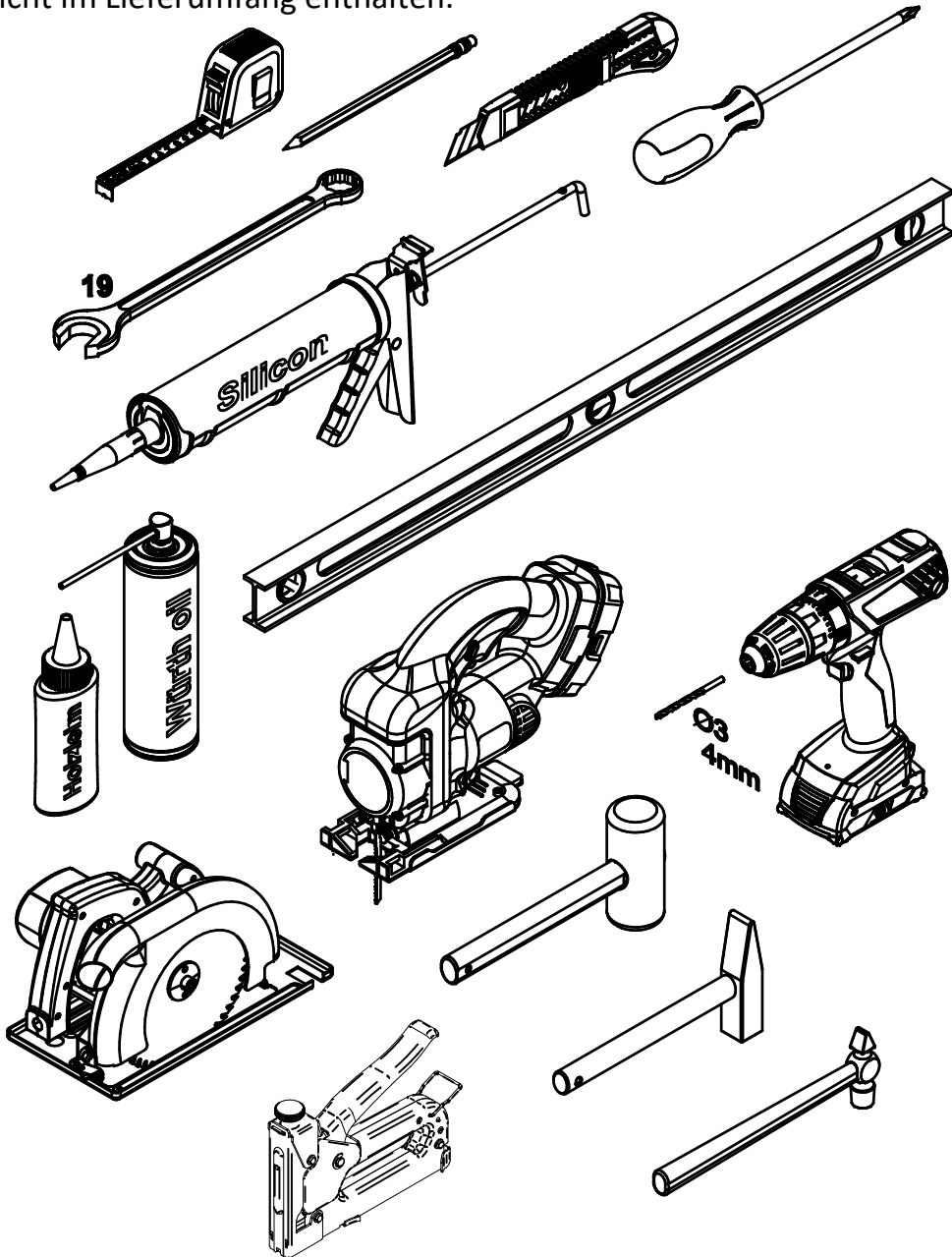





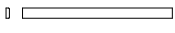

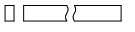

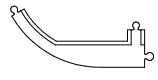
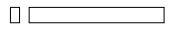

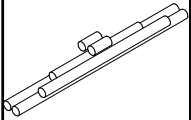
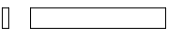
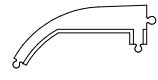
Werkzeuge, die Ihren Aufbau erleichtern.



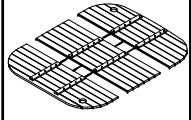
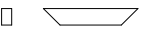
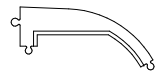

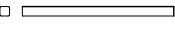
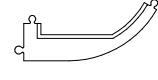
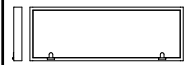
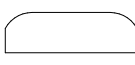



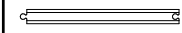





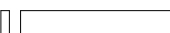

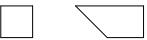

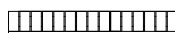

Nicht im Lieferumfang enthalten.



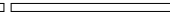
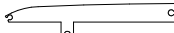
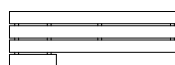



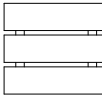
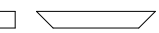

# BASE

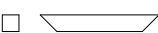
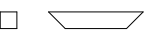
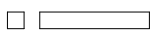
13.08.24

No.	L x W x H	Qt		No.	L x W x H	Qt		No.	L x W x H	Qt	
11	1192x120x68	4		102	660x45x15	2		621	Sperrholz Plywood 27mm	1	
12	1790x40x68	2		103	1690x28x28	2		622	Sperrholz Plywood 27mm	1	
13	595x40x68	2		104	646x28x28	2		623	Sperrholz Plywood 27mm	1	
21	D24	kit		121	595x90x28	3		624	Sperrholz Plywood 27mm	2	
31	1130x42x103	81 +1		122	450x90x28	1		625	Sperrholz Plywood 27mm	1	
51	2585x1958x28	1		123	300x40x28	1		626	Sperrholz Plywood 27mm	1	
71	1380x514	1		124	445x28x28	1		627	Sperrholz Plywood 27mm	1	
100	1690x590x100	1		161	Glas 1734x532	2		628	Sperrholz Plywood 27mm	1	
101	1670x45x15	2		162	Glas 1734x634	1		629	Sperrholz Plywood 27mm	1	

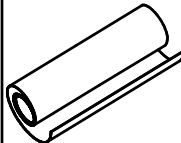
No.	L x W x H	Qt		No.	L x W x H	Qt		No.	L x W x H	Qt	
630	Sperrholz Plywood 27mm	1		811	1270x422x72	2		834	396x90x28	3	
631	Sperrholz Plywood 27mm	1		812	452x450x90	1		835	575x90x28	1	
632	Sperrholz Plywood 15mm	1		813	1560x90x28	1		839	60x28x28	14	
633	Sperrholz Plywood 15mm	2		814	980x90x28	1		901	Lüftungsgitter	1	
634	Sperrholz Plywood 15mm	2		821	1490x205x90	1		902	Lüftungsgitter	2	
635	Sperrholz Plywood 15mm	2		822	433x205x90	1		911	813x44x44	3	
636	Sperrholz Plywood 15mm	1		831	1265x405	1		912	813x44x44	2	
637	Sperrholz Plywood 15mm	1		832	900x302	1		931	120x44x44	4	
638	Sperrholz Plywood 15mm	1		833	400x302	1		932	378x44x44	1	

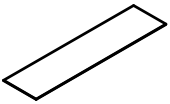
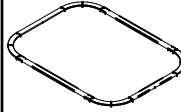
No.	L x W x H	Qt	
933	300x44x44	1	
934	250x44x44	4	
935	335x44x44	2	

Optional				13.08.24
No.	L x W x H	Qt		
4	1130x44x44	2		
141	4500x1500	1		
142	L1000x320	52		
143	L1000x250	2		
151	Holz Arch	kit		
H	Nagel Nail	kit		
B	4,5x60	54		

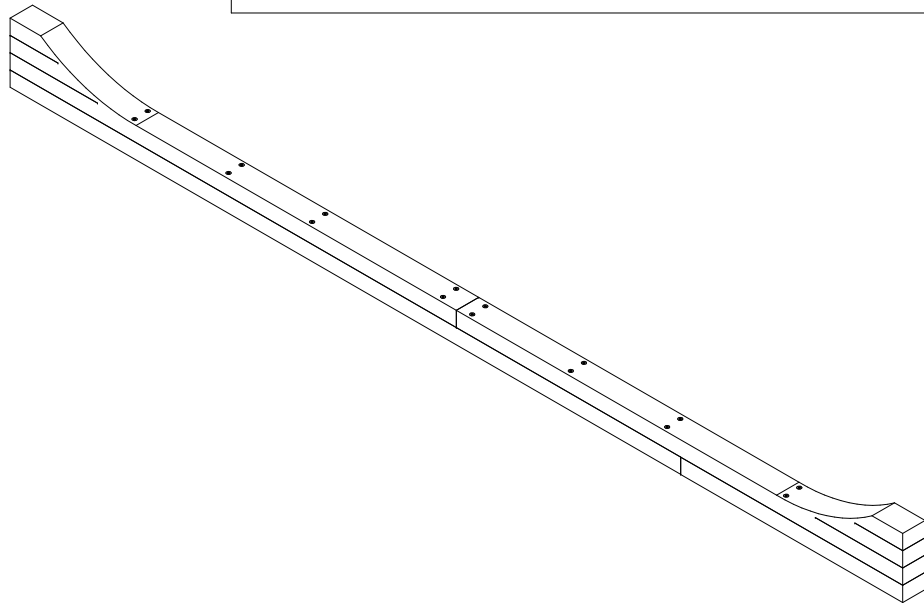
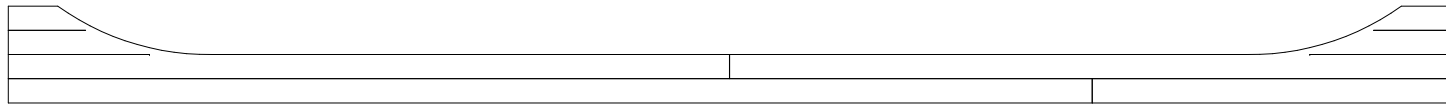
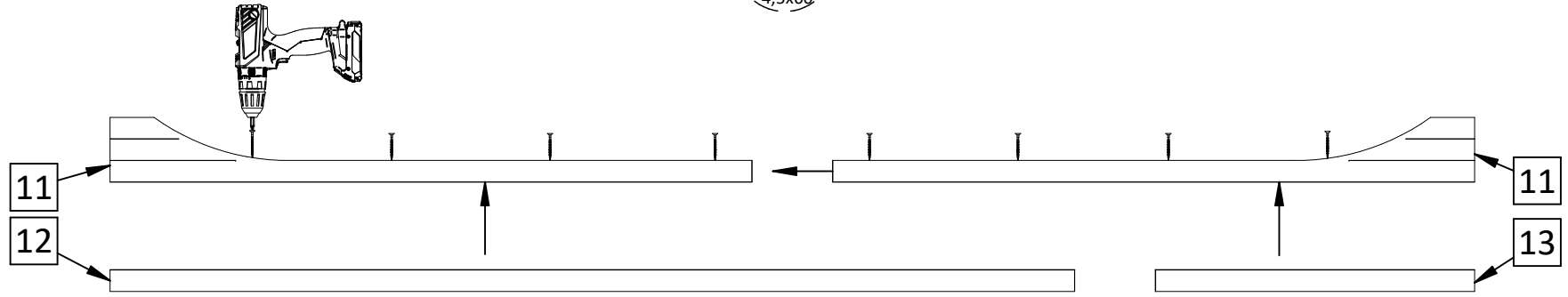
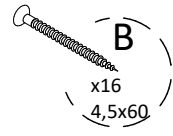

# FOUNDATION PLAN FUNDAMENTPLAN

Use a spirit level  
Benutzen Sie eine Wasserwaage

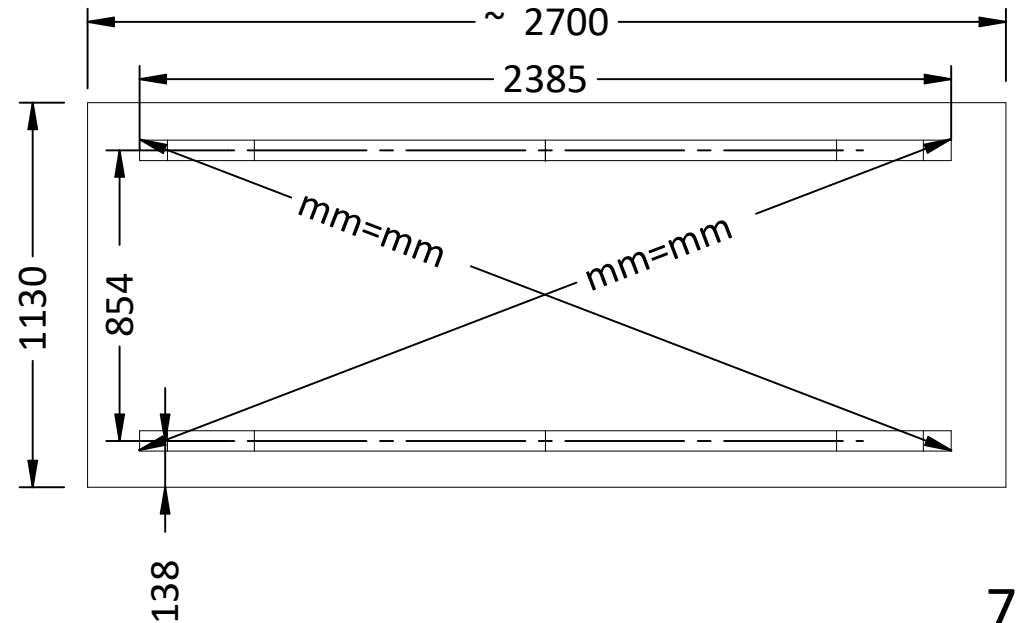
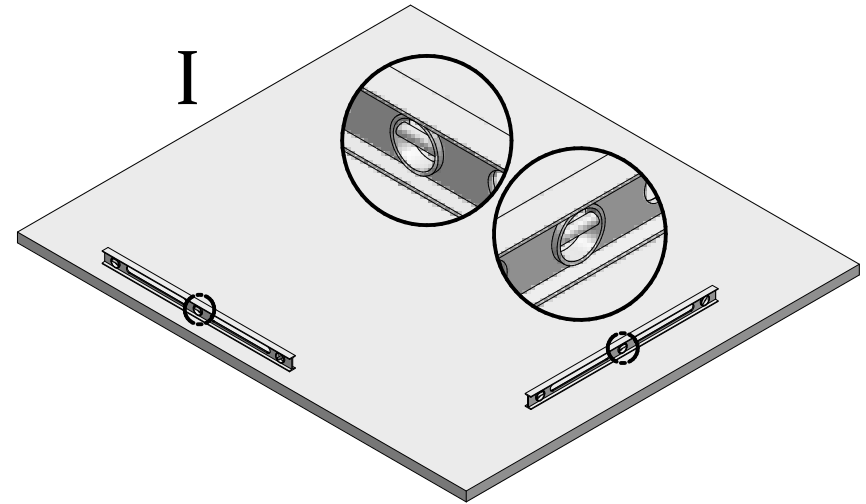
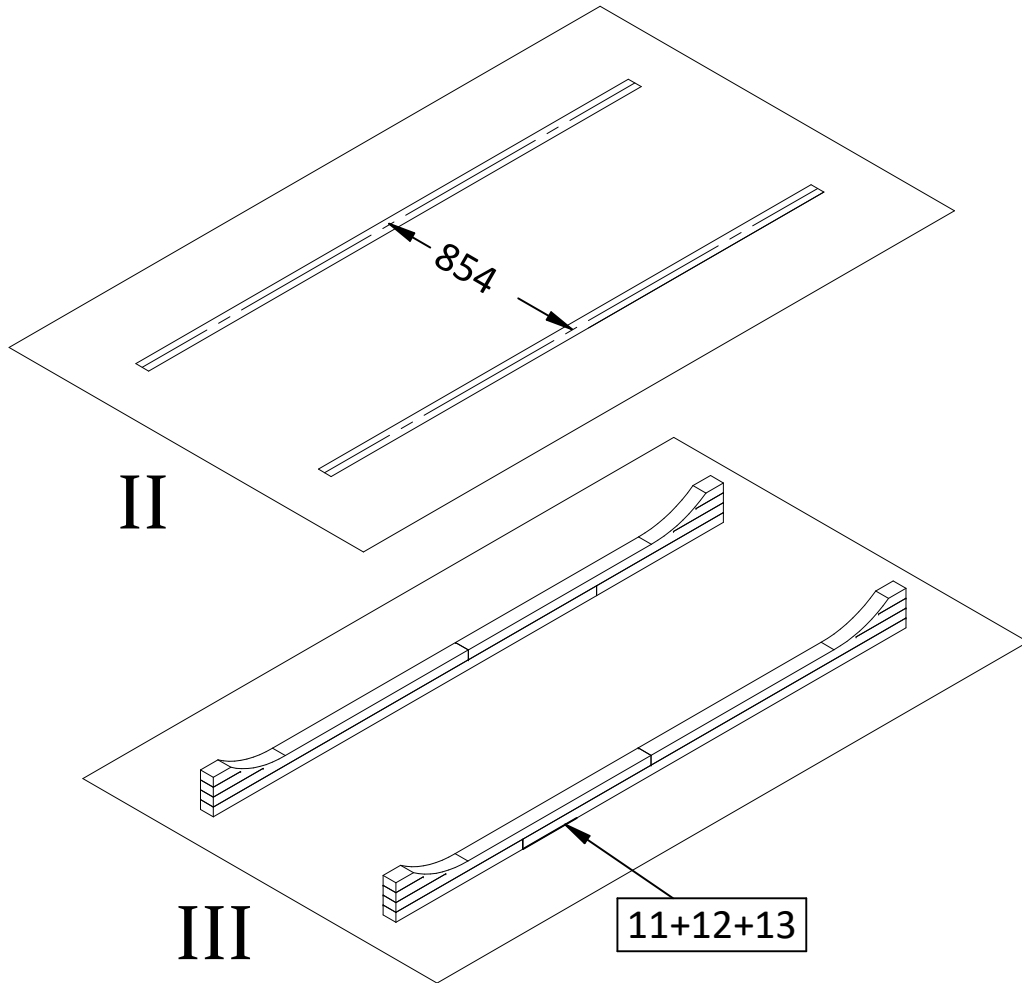

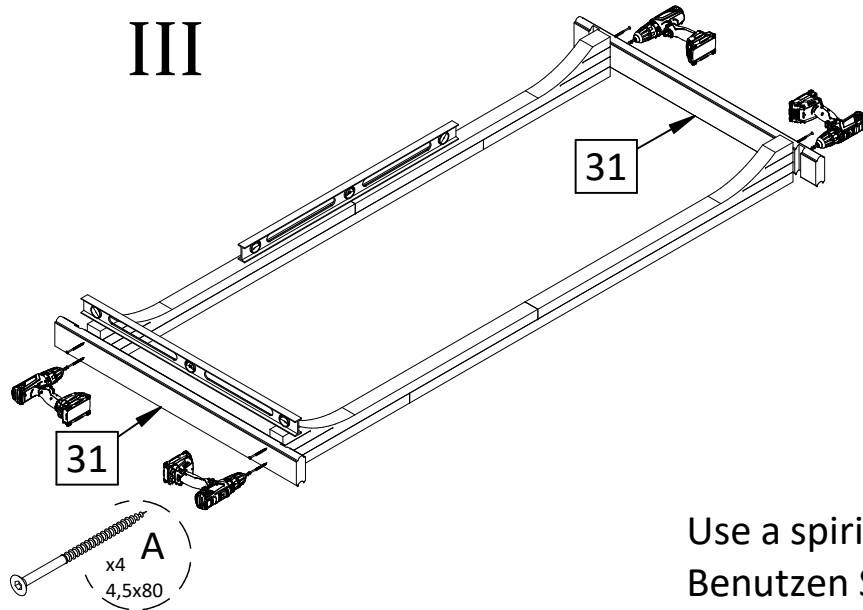
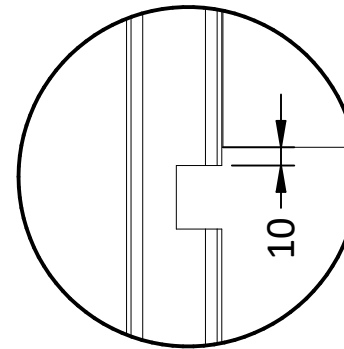
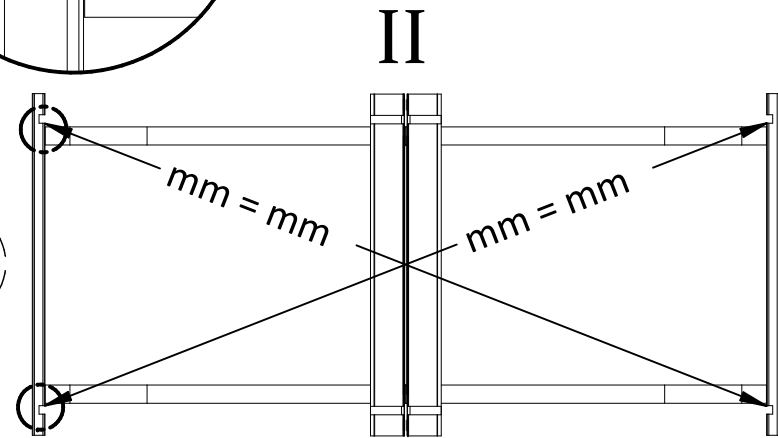
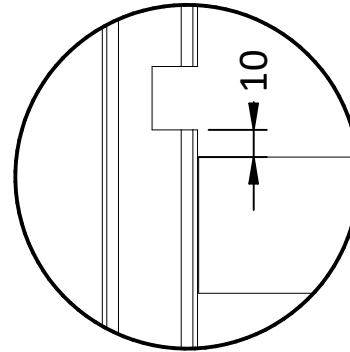
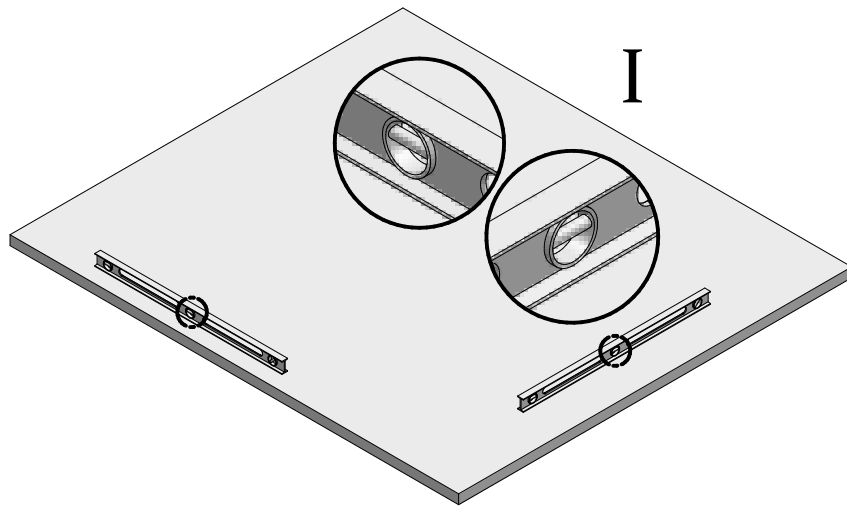

Use a spirit level  
Benutzen Sie eine Wasserwaage

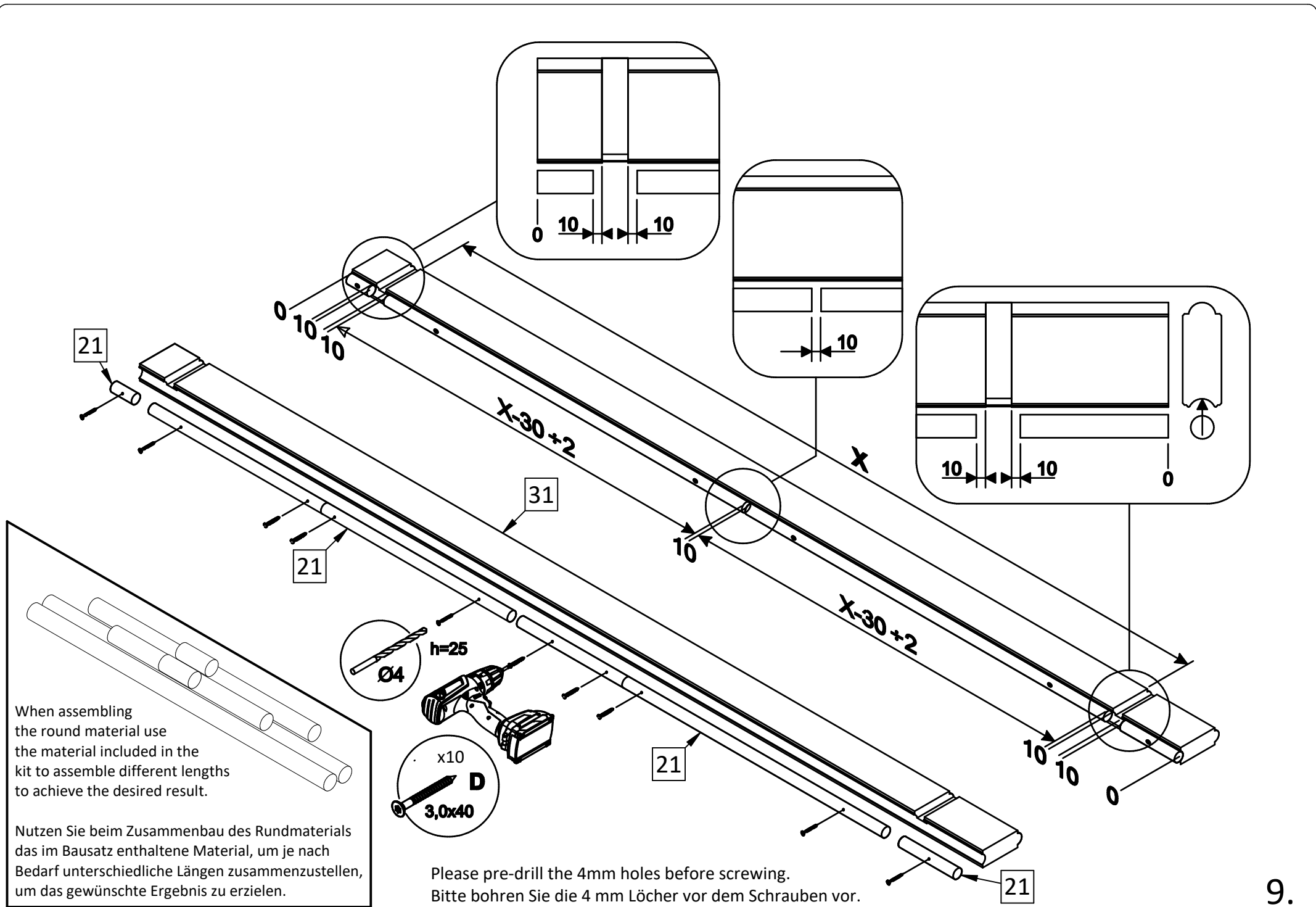

When assembling the round material use the material included in the kit to assemble different lengths to achieve the desired result.

Nutzen Sie beim Zusammenbau des Rundmaterials das im Bausatz enthaltene Material, um je nach Bedarf unterschiedliche Längen zusammenzustellen, um das gewünschte Ergebnis zu erzielen.

Please pre-drill the 4mm holes before screwing.  
Bitte bohren Sie die 4 mm Löcher vor dem Schrauben vor.

II

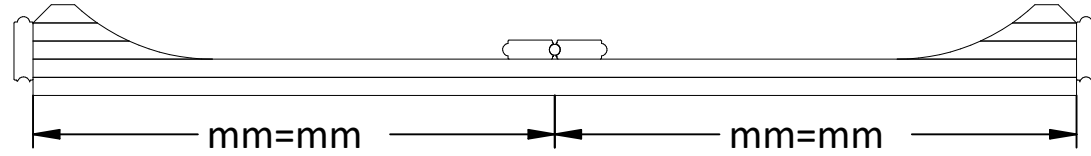
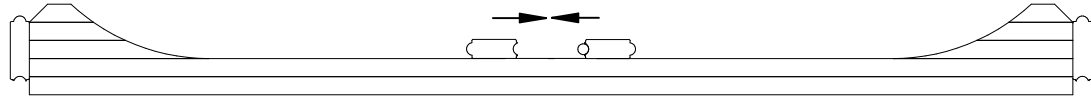

I

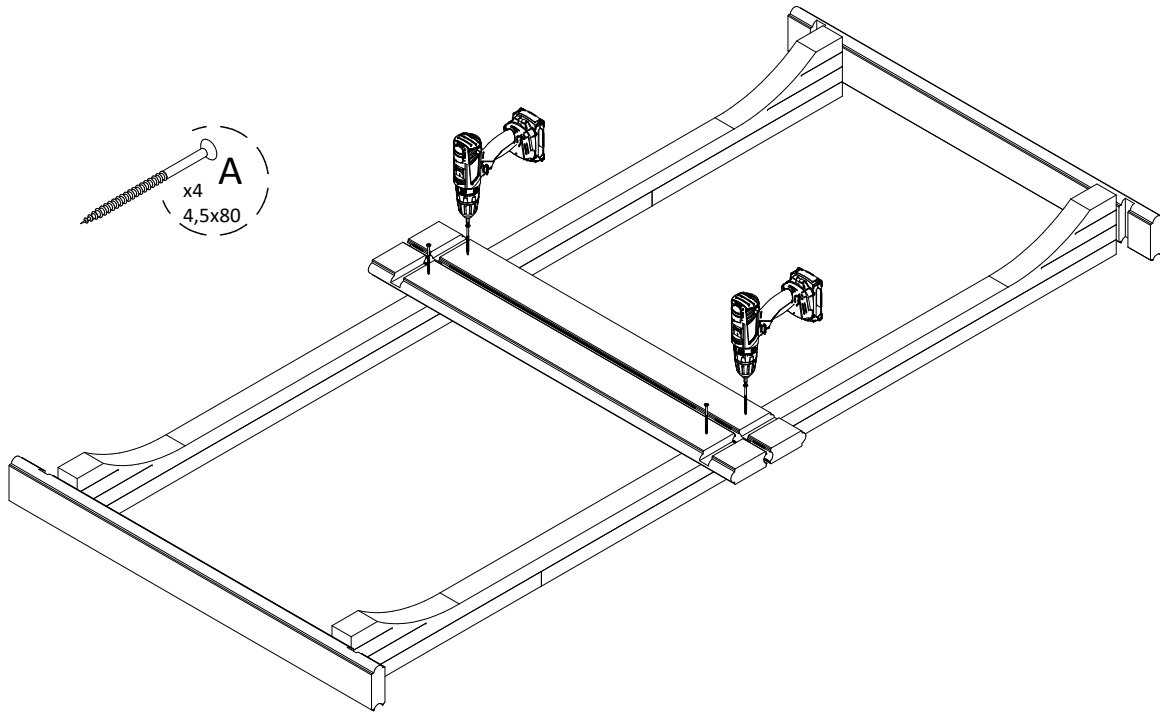
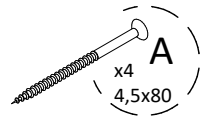
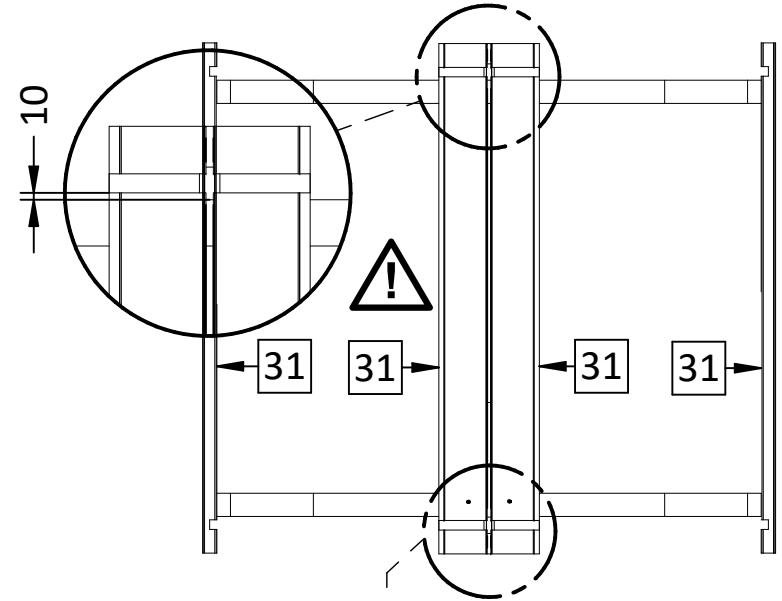

Use a spirit level  
Benutzen Sie eine Wasserwaage

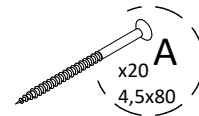
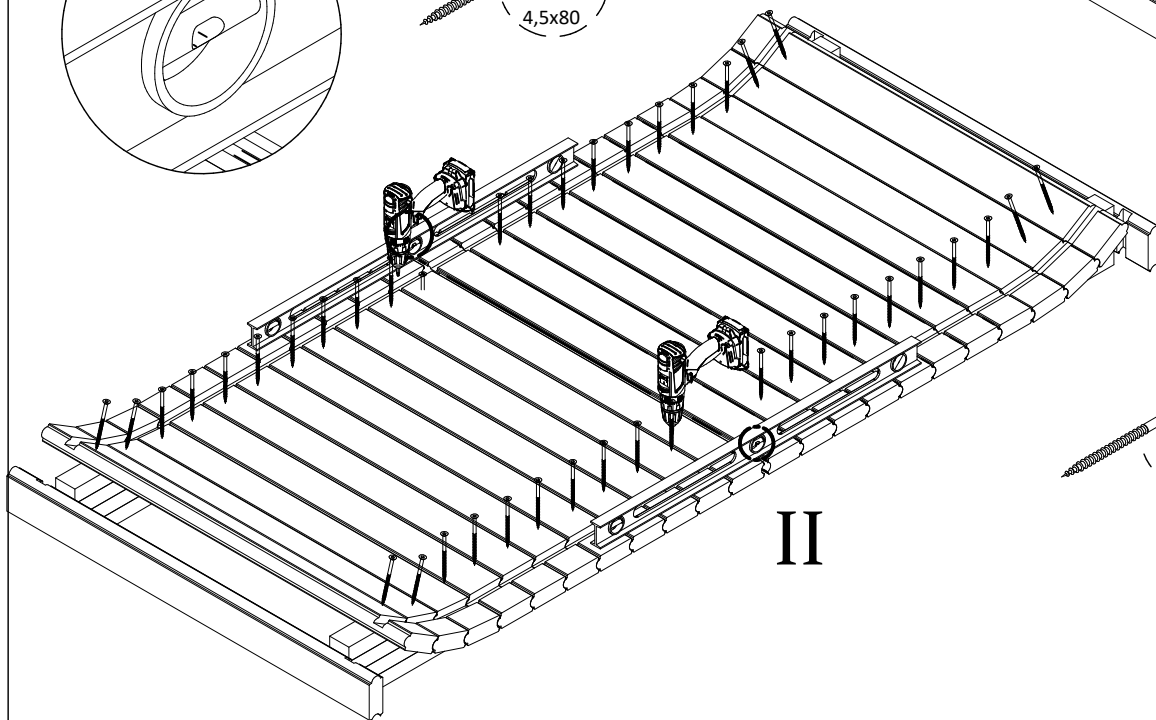
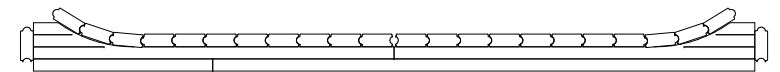
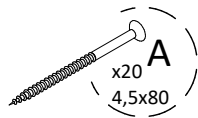
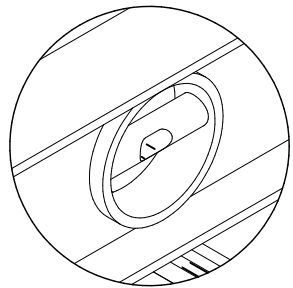
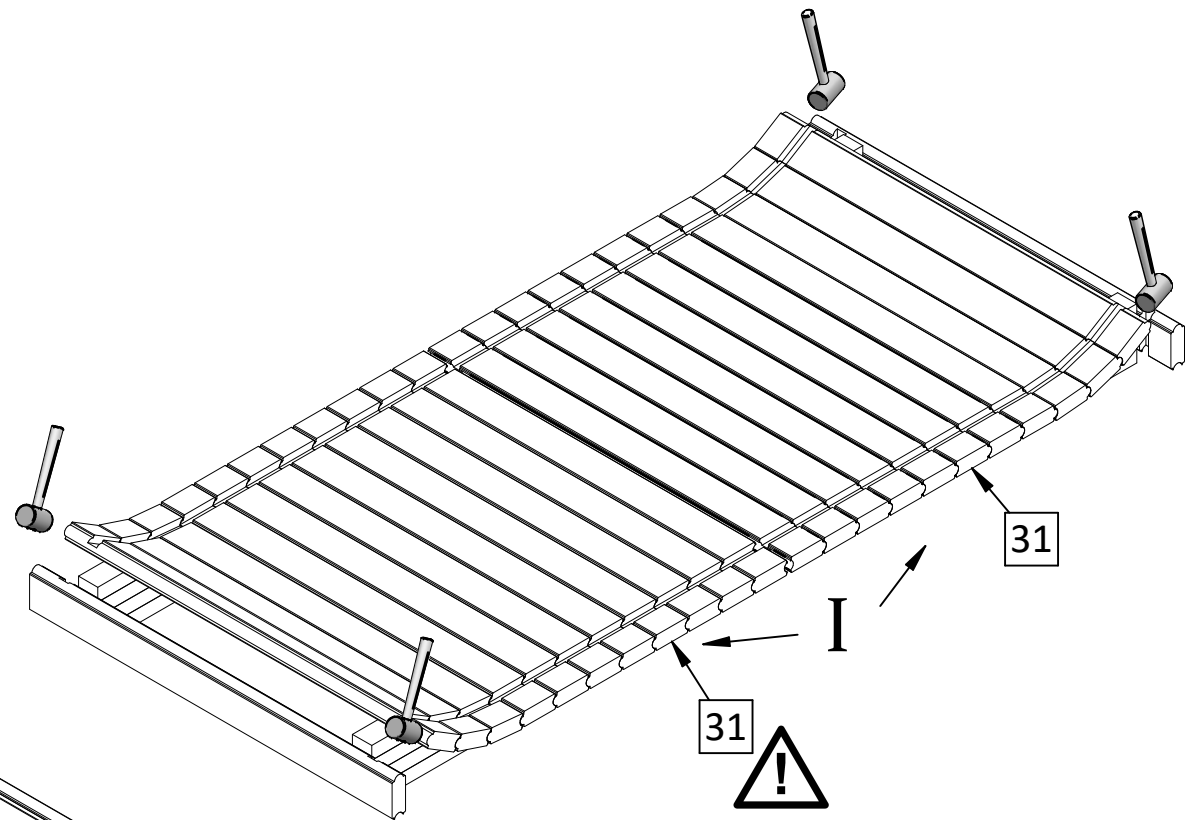

Use a piece of wood to protect plywood.

Verwenden Sie ein Stück Holz um das Sperrholz zu schützen.



624

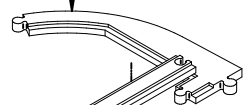
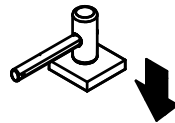

623

629

625

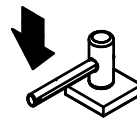

626

622

628

h=27

630

631

621

627

630

623

623

635

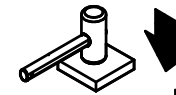

636

637

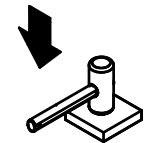

634

638

638

h=15

638

633

632

634

Use a piece of wood to protect plywood.

635

Verwenden Sie ein Stück Holz um das Sperrholz zu schützen.



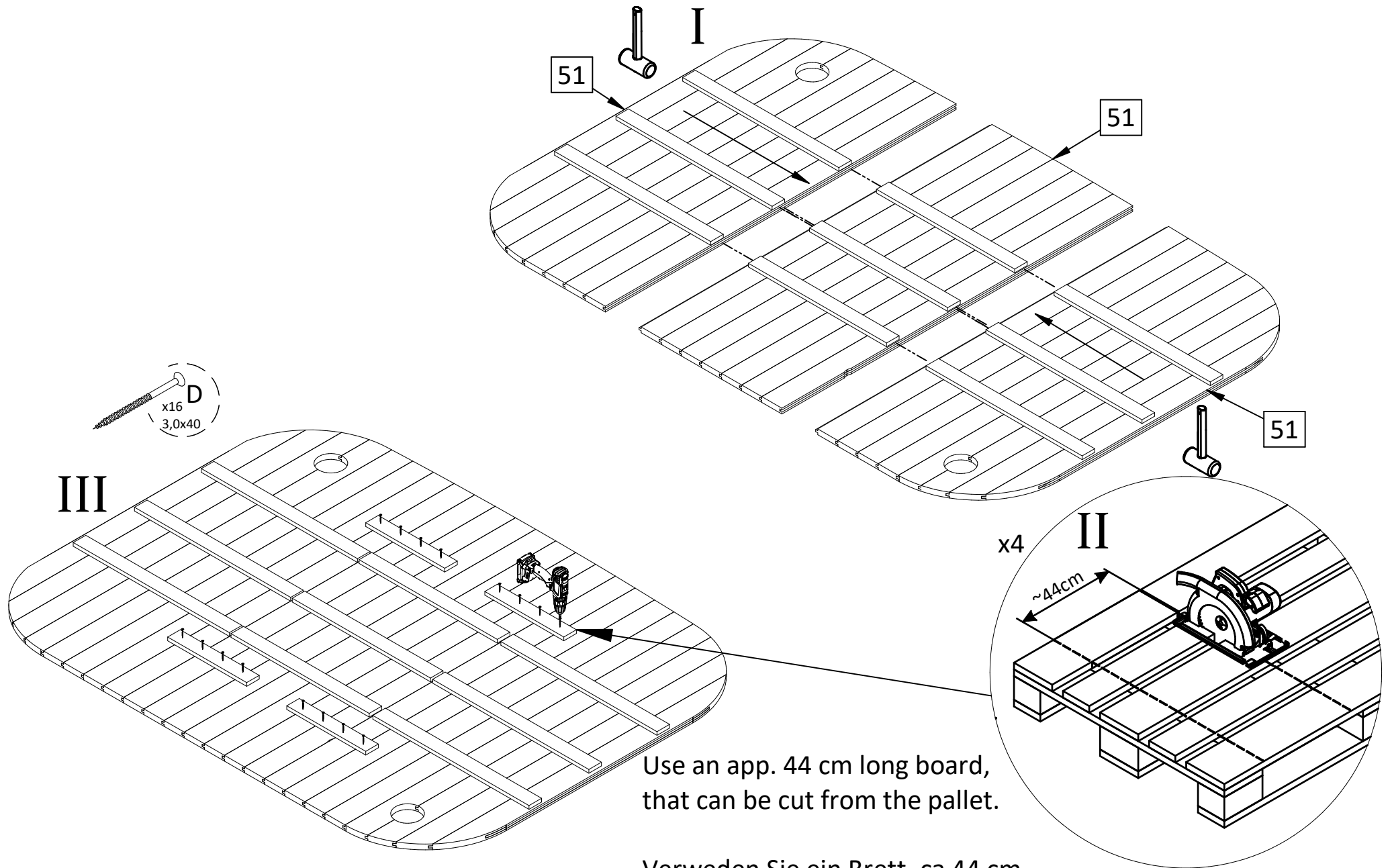

Use an app. 44 cm long board,  
that can be cut from the pallet.

Verwenden Sie ein Brett, ca 44 cm,  
das von der Palette abgeschnitten  
werden kann.

Use a spirit level  
Benutzen Sie eine Wasserwaage

II

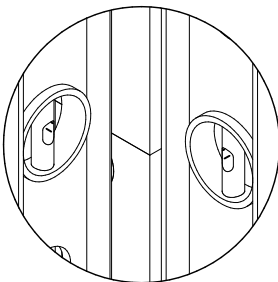

621-631

Important! Keep your distance!  
Don't leave a gap if  
the sauna is made of  
thermowood.



Wichtig! Abstand halten!  
Keine Lücke lassen,  
falls Sauna aus Thermoholz ist.

8

~7 mm

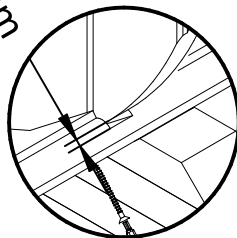

B  
x2  
4,5x60

51

III

B  
x2  
4,5x60

IV

B  
x4  
4,5x60

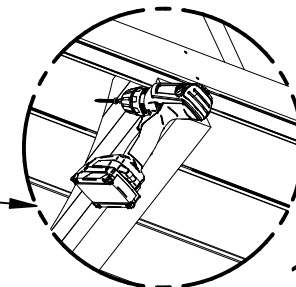

Important! Keep your distance!  
 Don't leave a gap if  
 the sauna is made of  
 thermowood.

Wichtig! Abstand halten!  
 Keine Lücke lassen,  
 falls Sauna aus  
 Thermoholz ist.

Remove the screws.  
 Die Schrauben entfernen.

Important! Please remove  
 the screws and use them  
 for further assembly.

Wichtig! Bitte entfernen Sie  
 die Schrauben und benutzen sie  
 die bei der weiteren Montage

Remove the screws.  
 Die Schrauben entfernen.

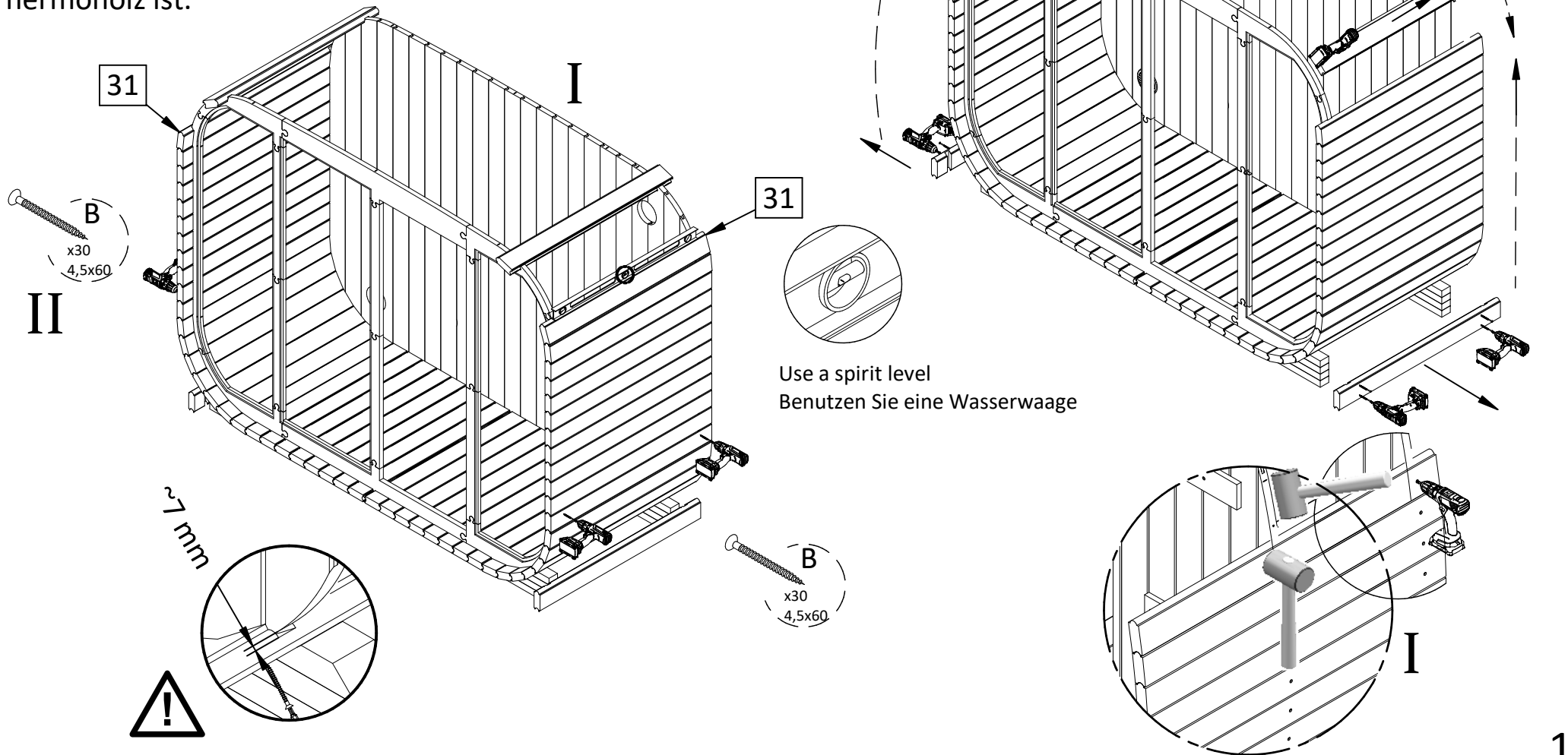

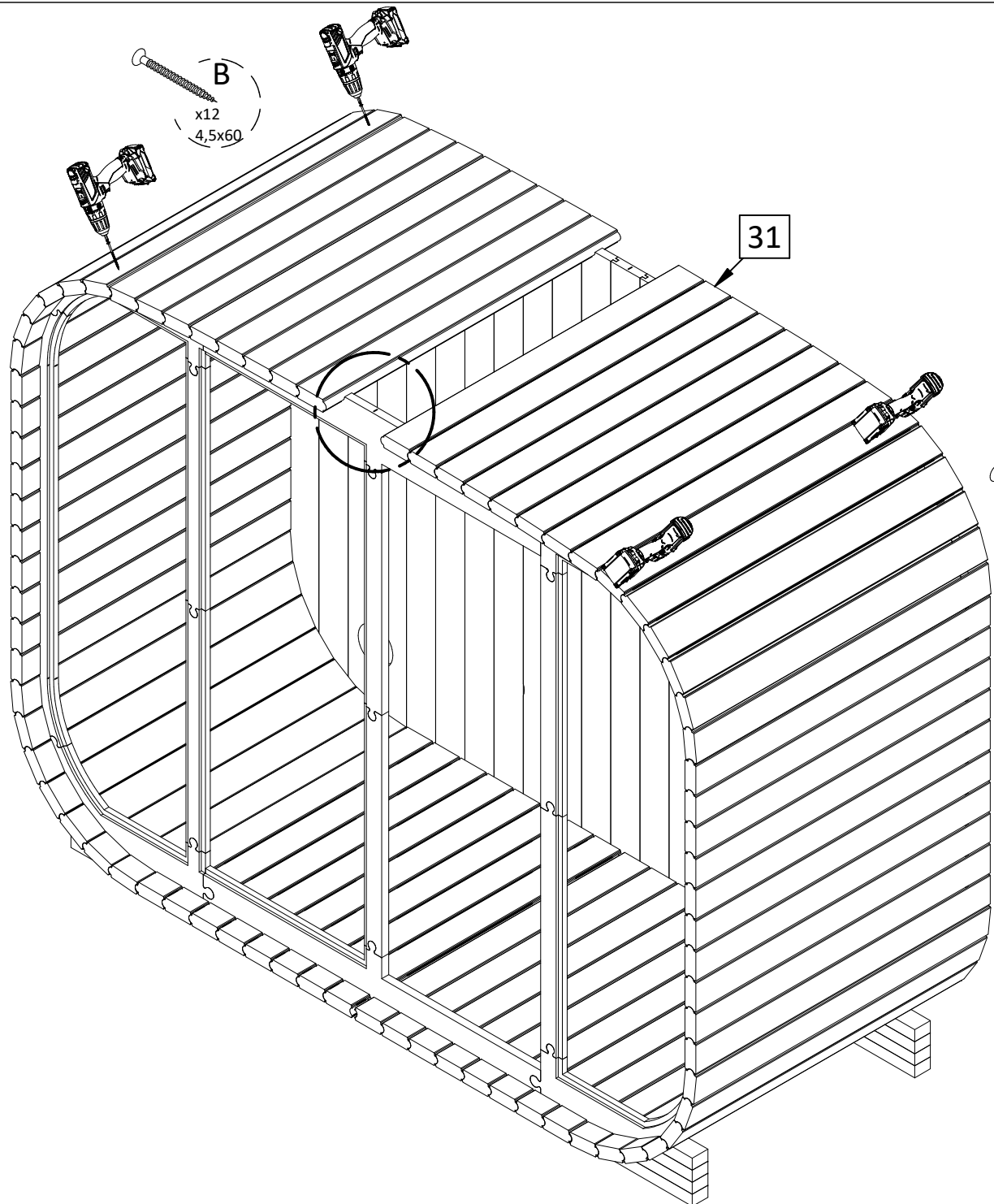
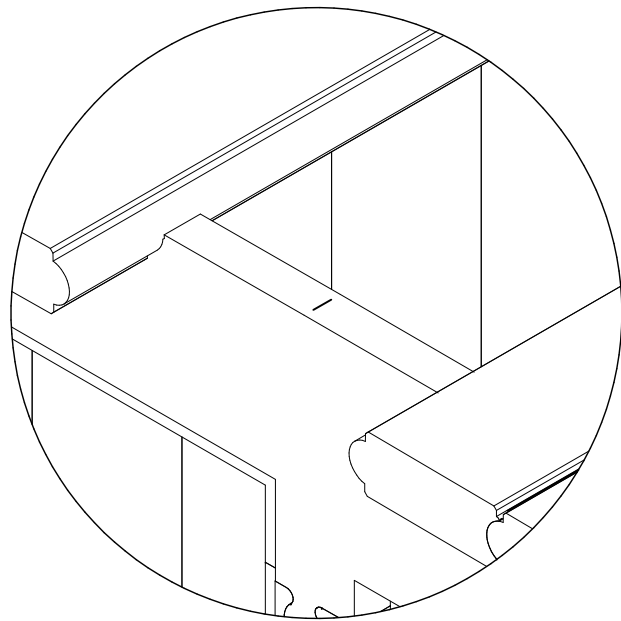

B  
x12  
4,5x60

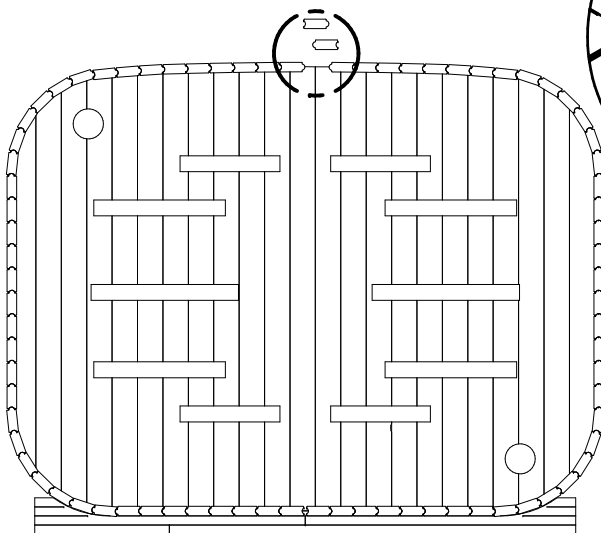
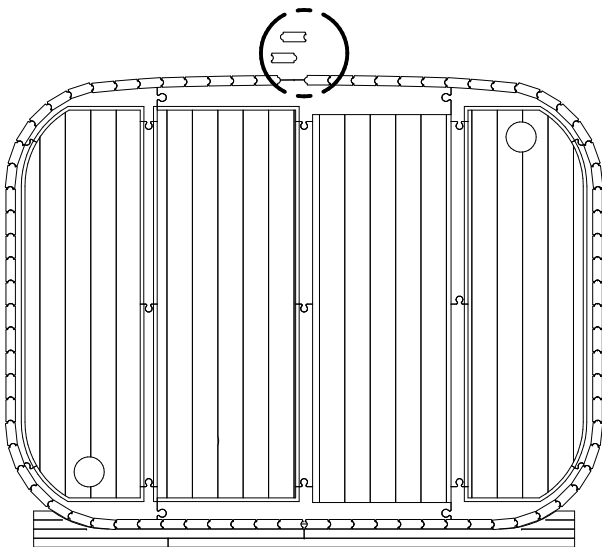
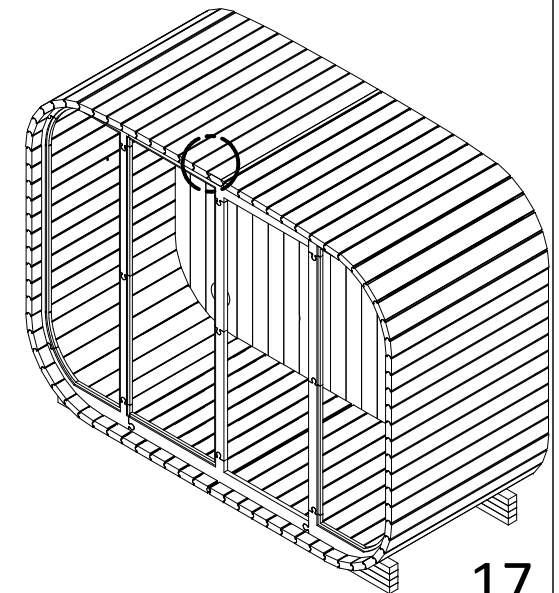
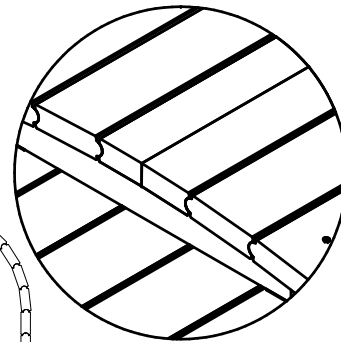
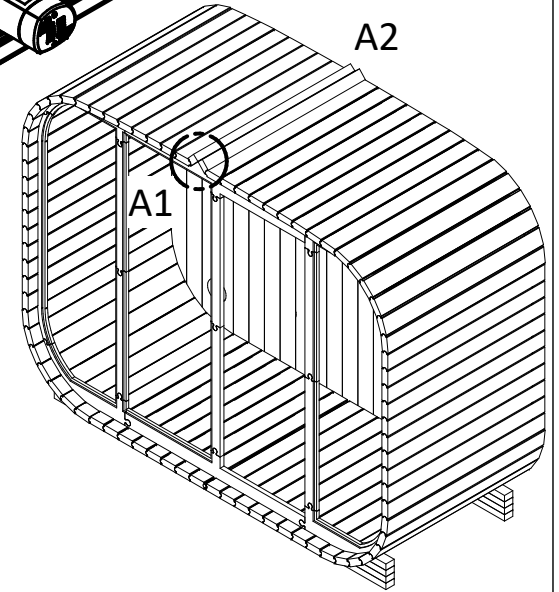
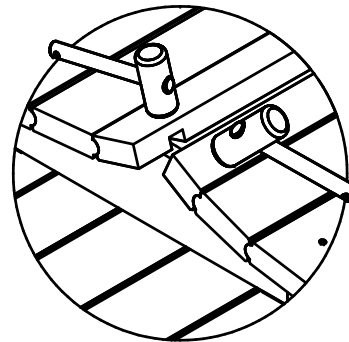
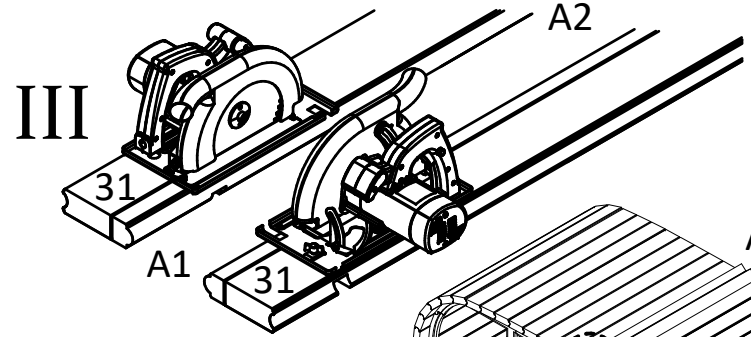
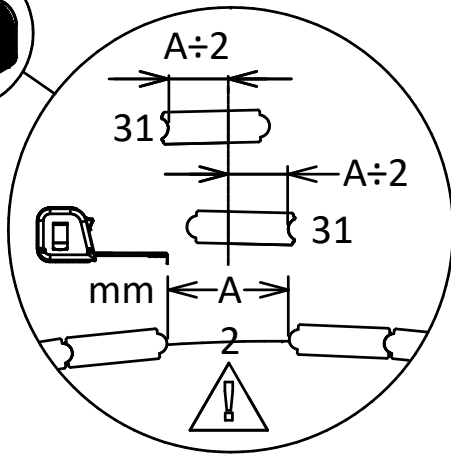
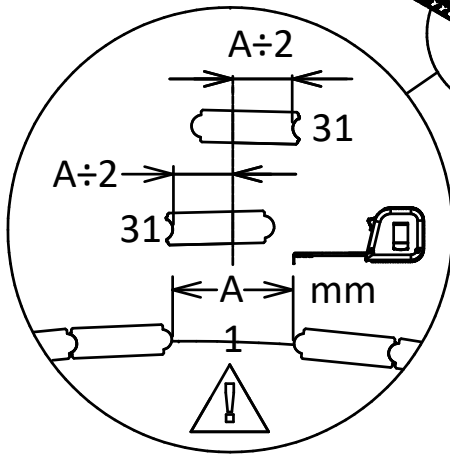
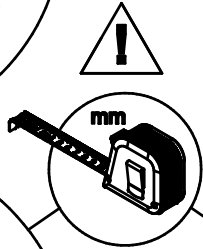
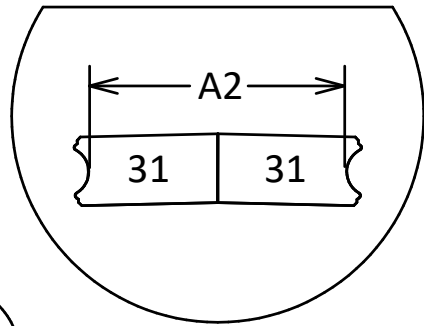
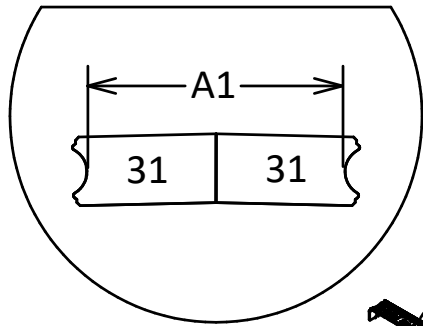

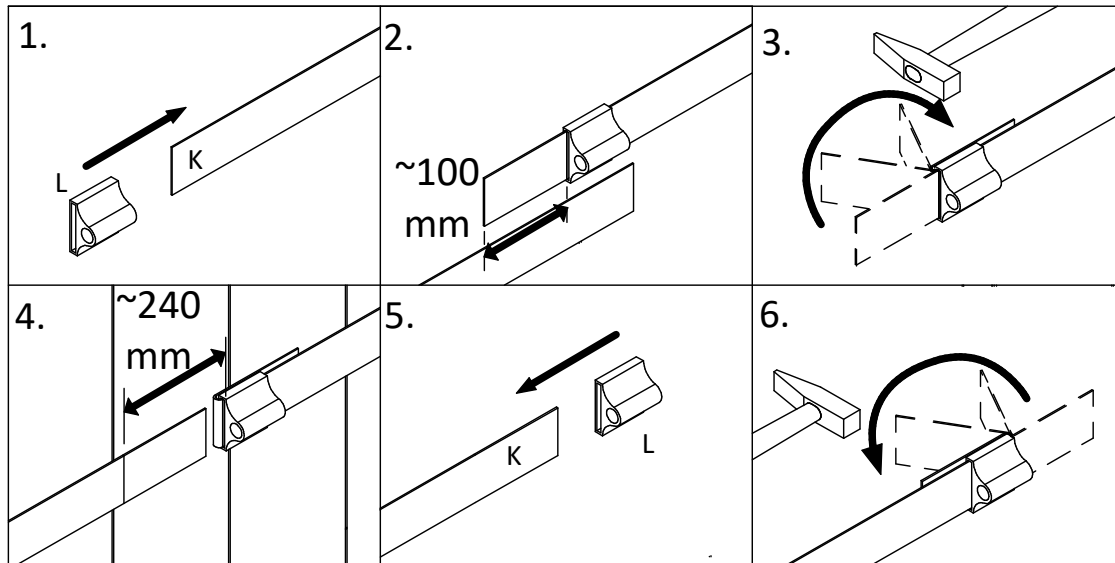

Die Schrauben entfernen.  
Remove the screws.

**II**

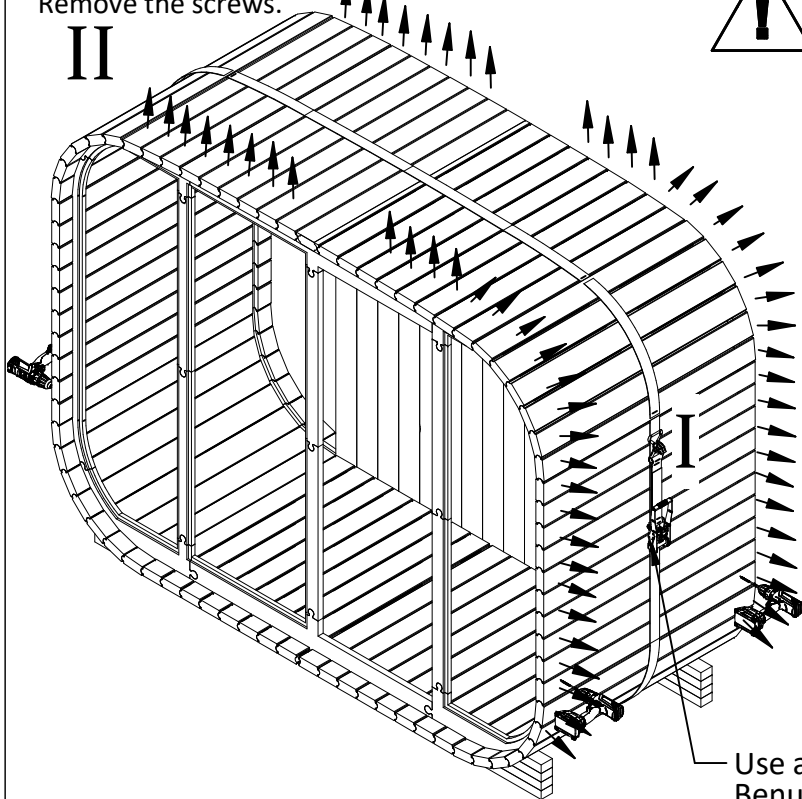

Use a ratchet strap.  
Benutzen sie ein Spannband.

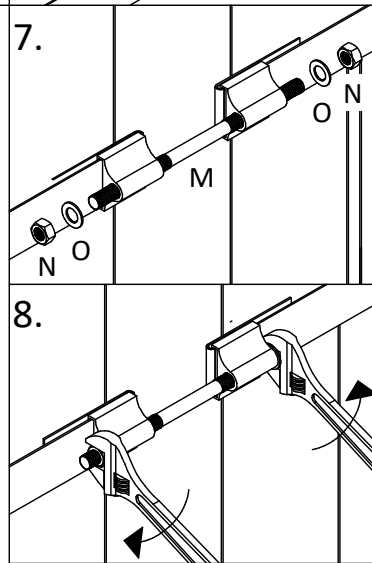

Important! If you have a thermo wood sauna barrel, please do not remove the screws.  
Wichtig! Wenn Sie ein Saunafaß aus Thermoholz haben, entfernen Sie bitte nicht die Schrauben.

**IV**

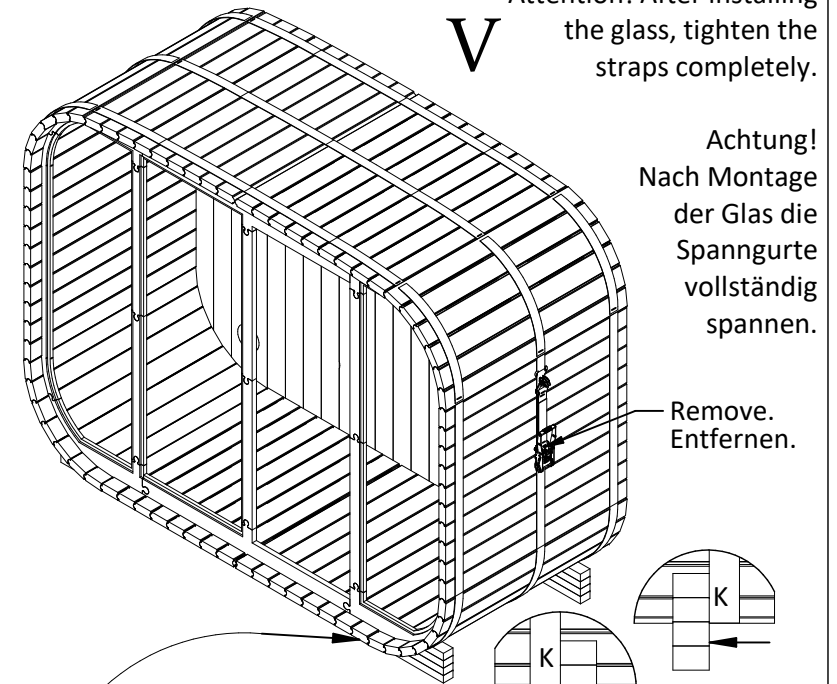

Attention! After installing the glass, tighten the straps completely.

**V**

Achtung! Nach Montage der Glas die Spanngurte vollständig spannen.

Remove.  
Entfernen.

Attention! When assembling and maintaining/retightening the threaded rods, the threaded rods must be oiled with oil (W44 or Würth HPS1400). In this way, damage to the threaded rod can be avoided and it can be clamped more easily.

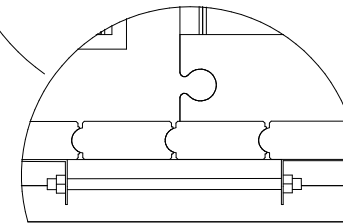

Achtung! Bei der Montage und bei der Pflege/Nachspannen der Gewindestangen, ist die Gewindestange mit Öl (W44 oder Würth HPS1400) zu ölen. So kann eine Beschädigung an der Gewindestange vermieden werden und man kann es leichter spannen.

Before processing the screws.

Pre-drill the holes  
with a 4 mm drill bit.

Bitte bohren Sie  
die  $\phi 4$ mm Löcher vor  
dem Schrauben vor

Use a spirit level  
Benutzen Sie eine  
Wasserwaage

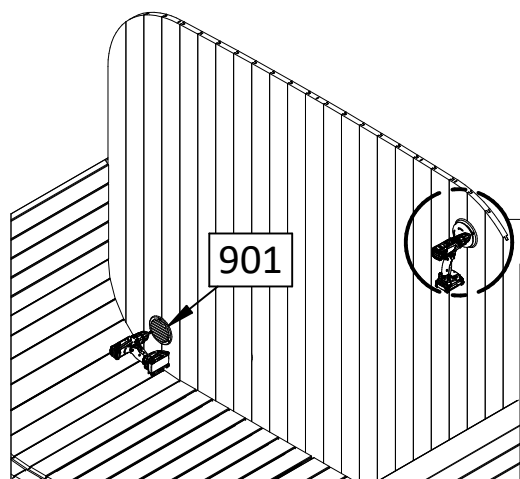
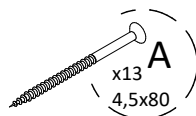
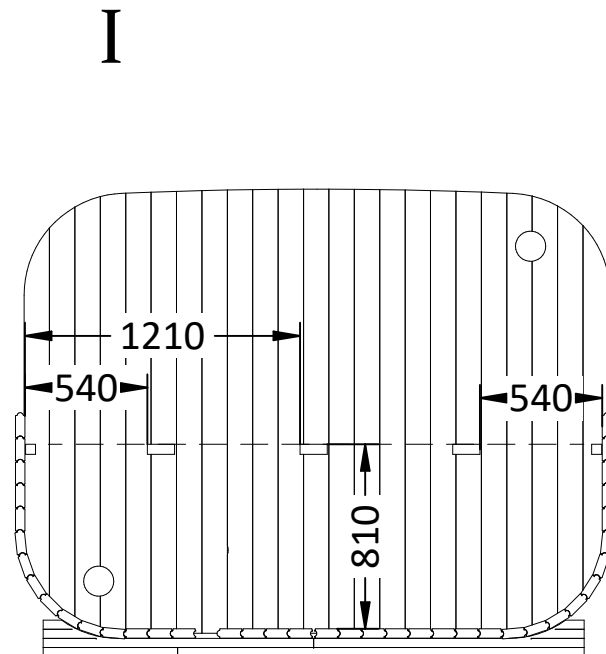
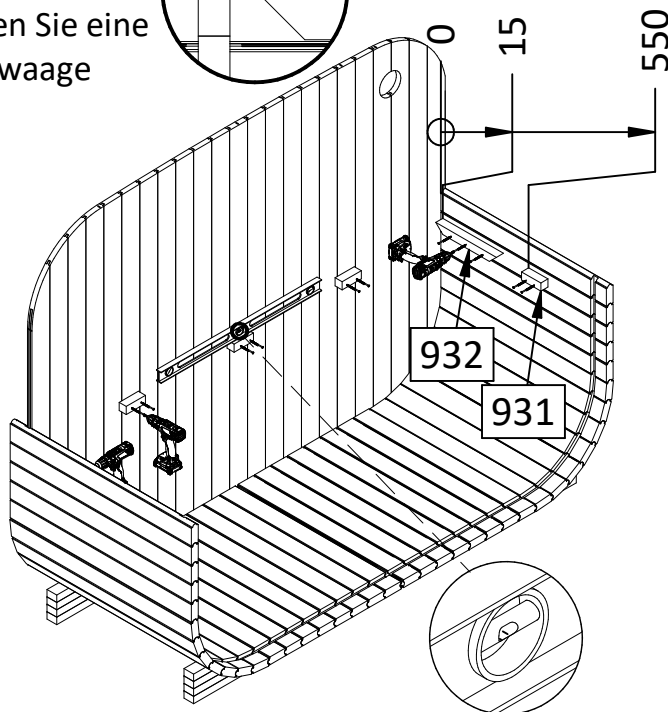
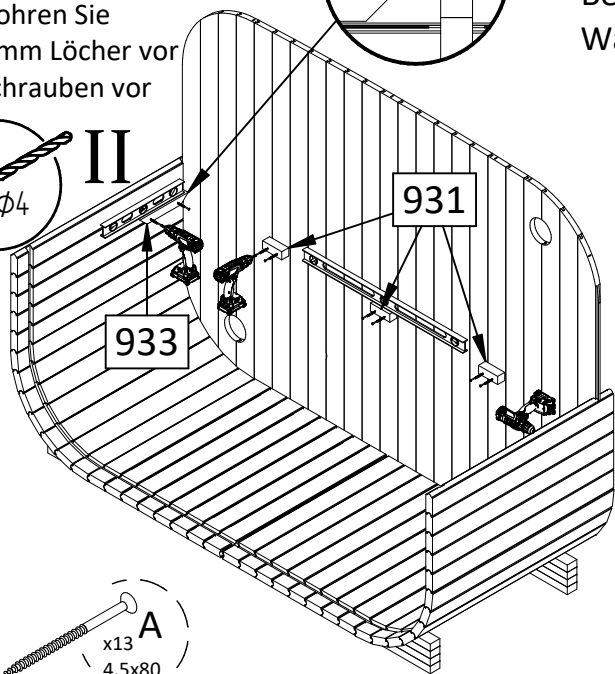
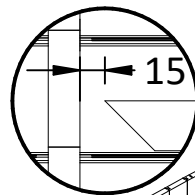
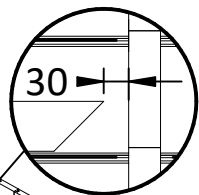
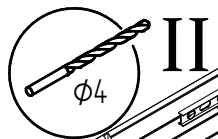

III

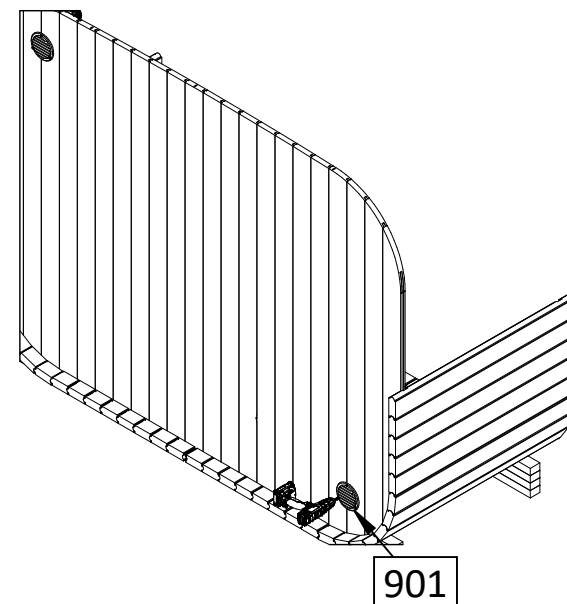
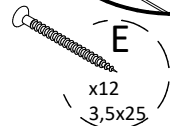
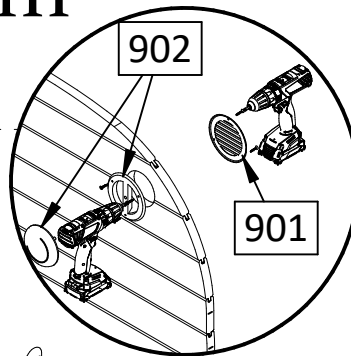

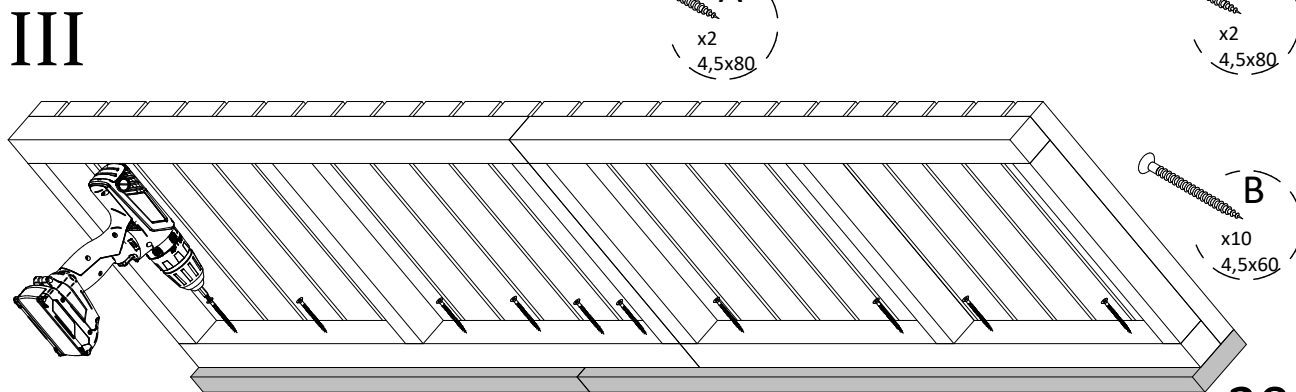
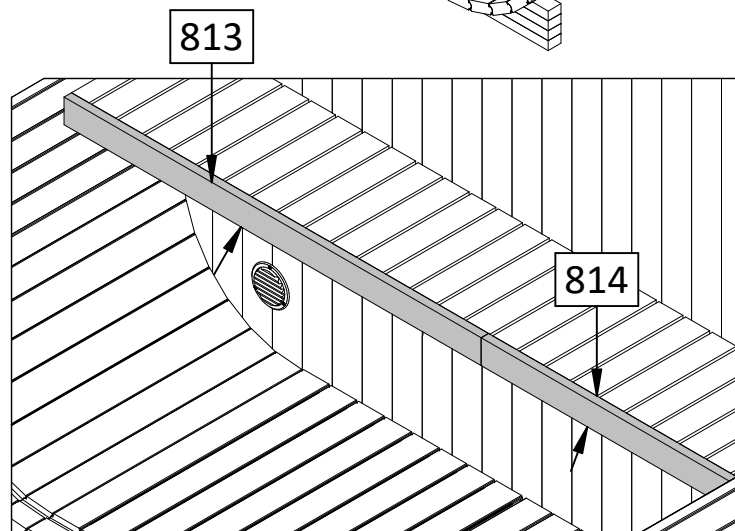
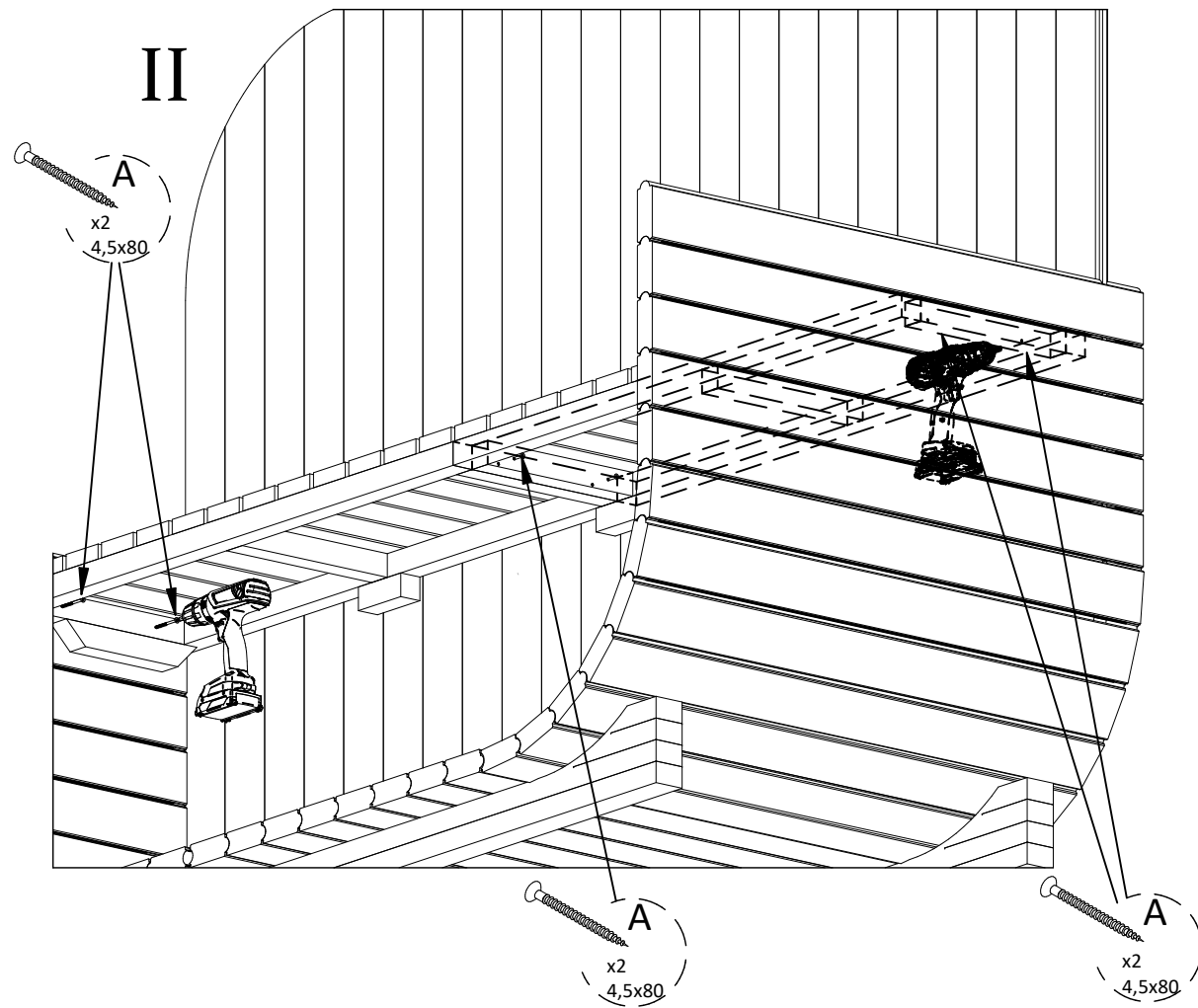
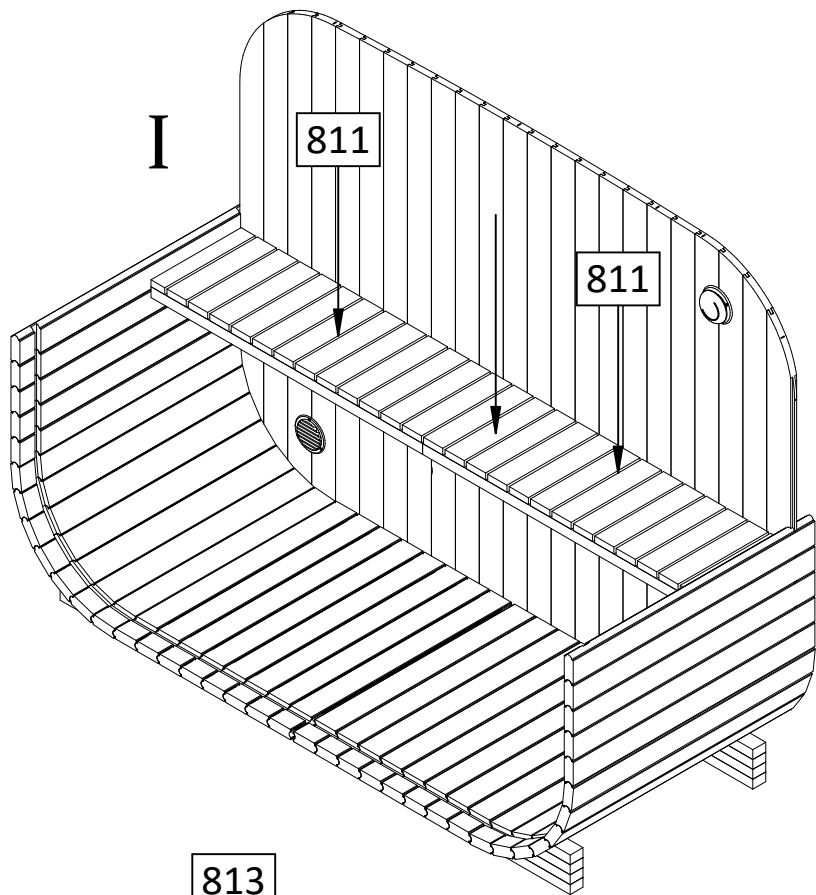

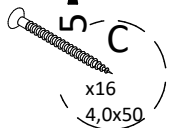
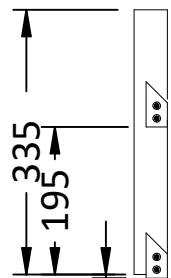

Before processing the screws.  
Pre-drill the holes  
with a 4 mm drill bit.

Bitte bohren Sie  
die  $\phi 4$ mm Löcher vor  
dem Schrauben vor

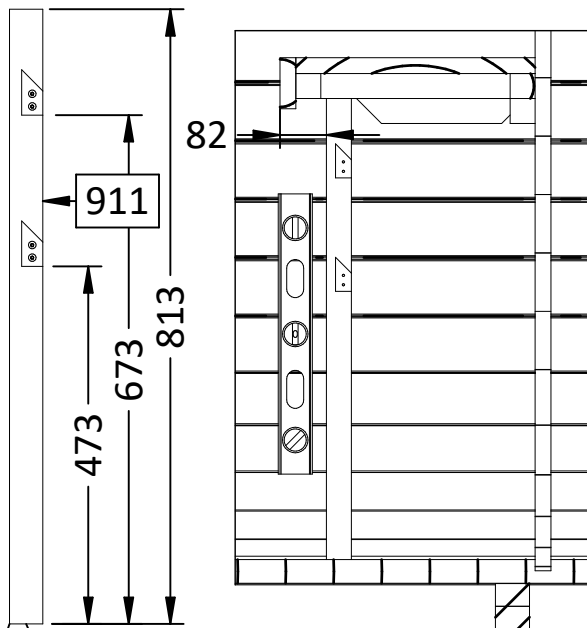
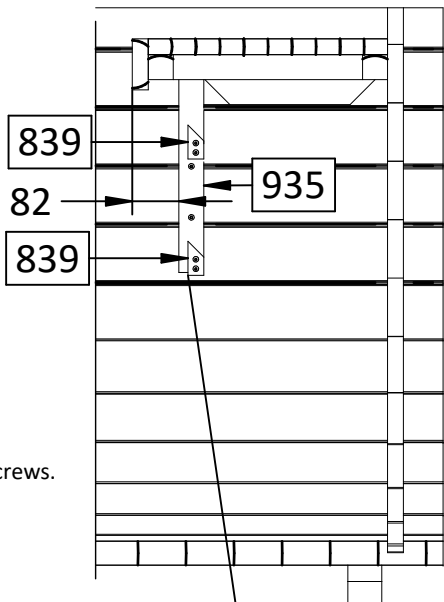

2x

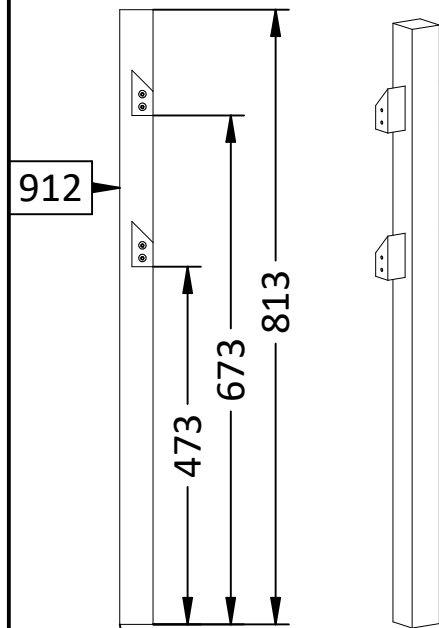

Before processing the screws.  
Pre-drill the holes  
with a 4 mm drill bit.

Bitte bohren Sie  
die  $\phi 4$ mm Löcher vor  
dem Schrauben vor

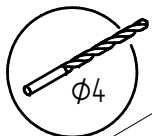

Use a spirit level  
Benutzen Sie eine  
Wasserwaage

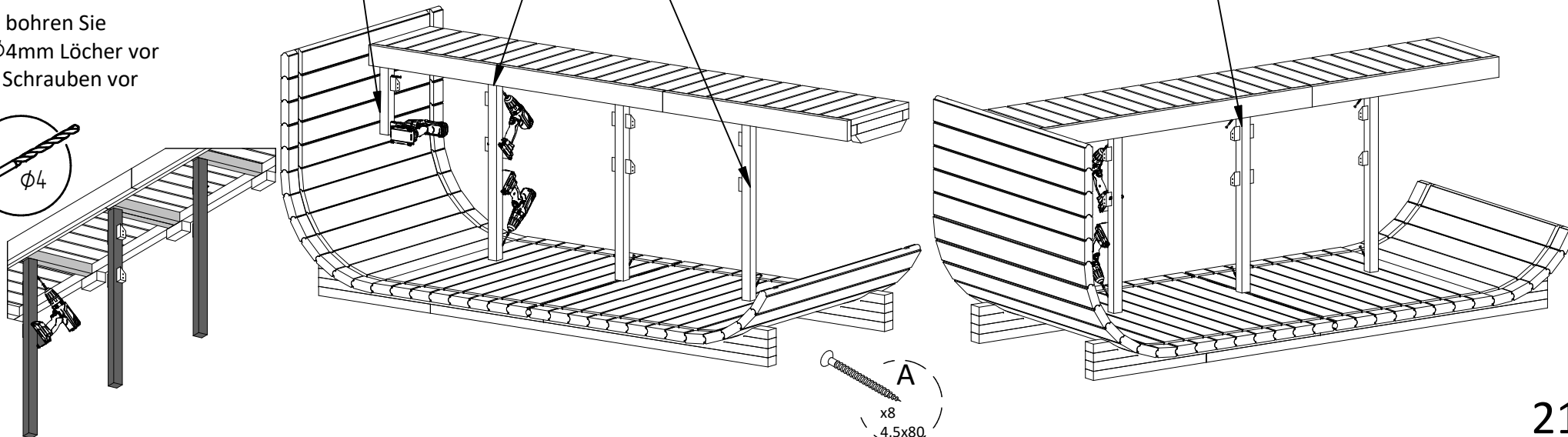

I

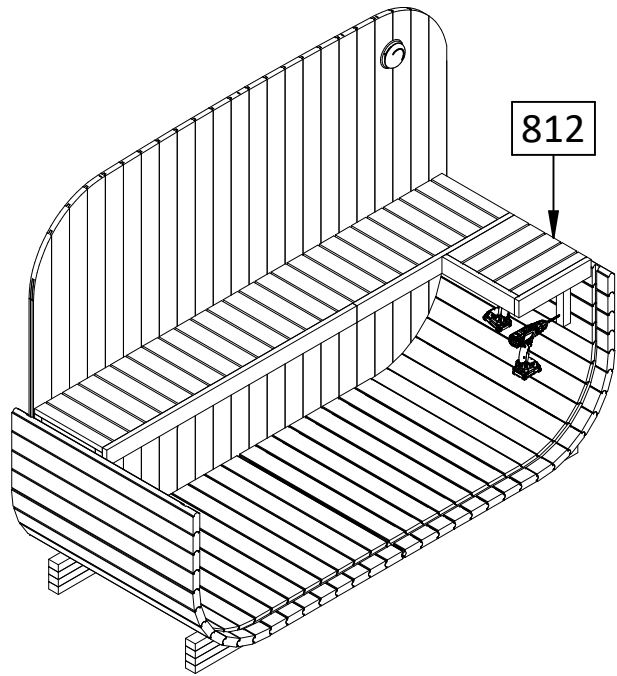

II

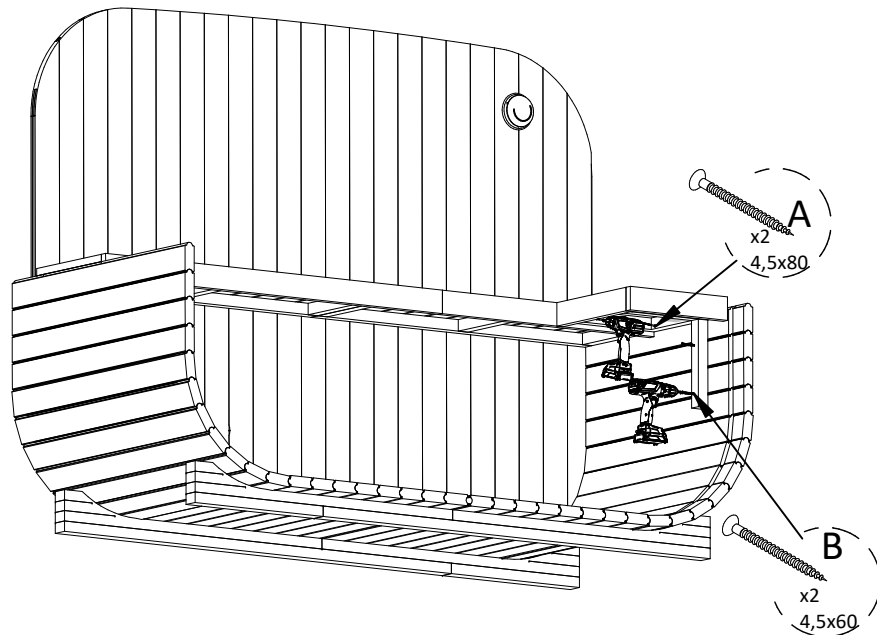

III

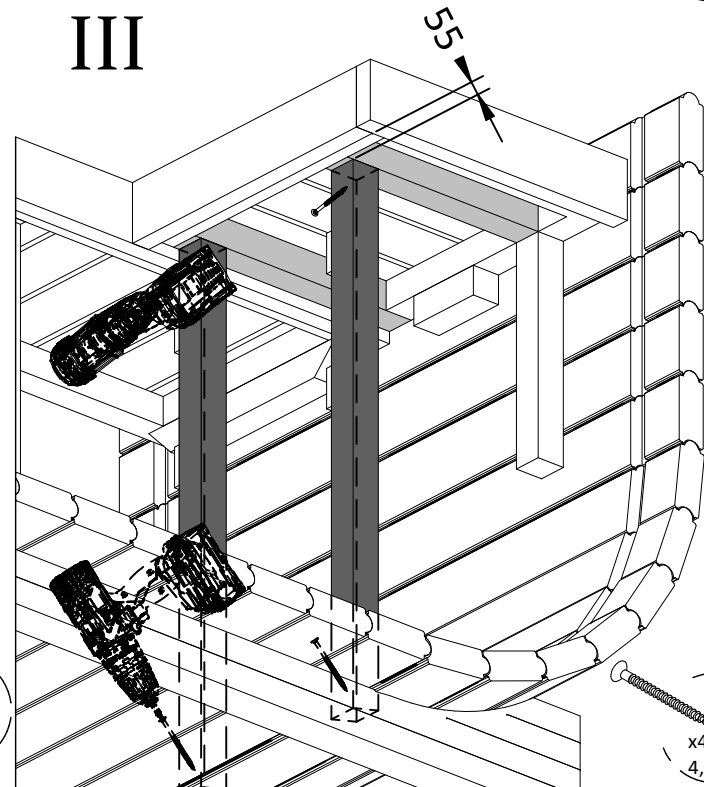
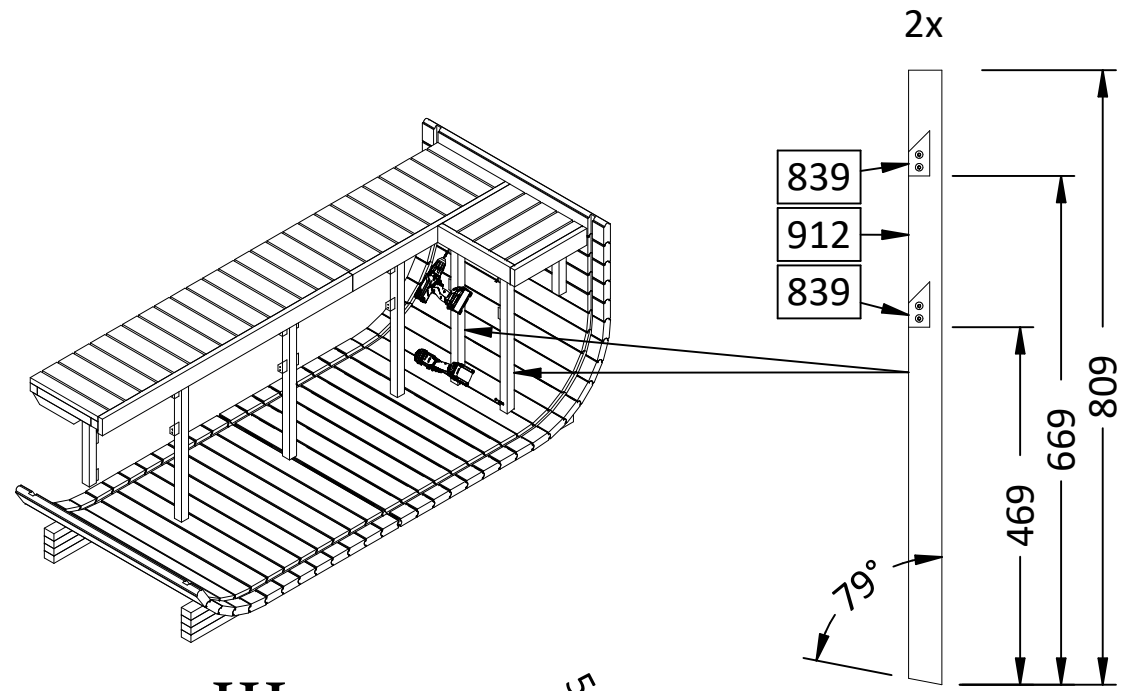

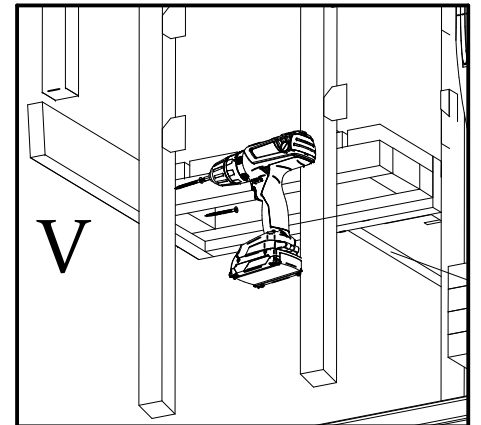
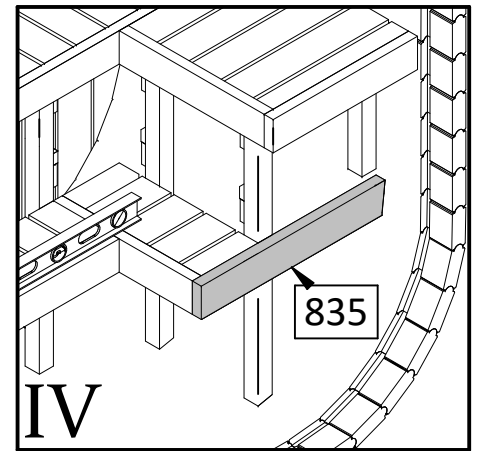
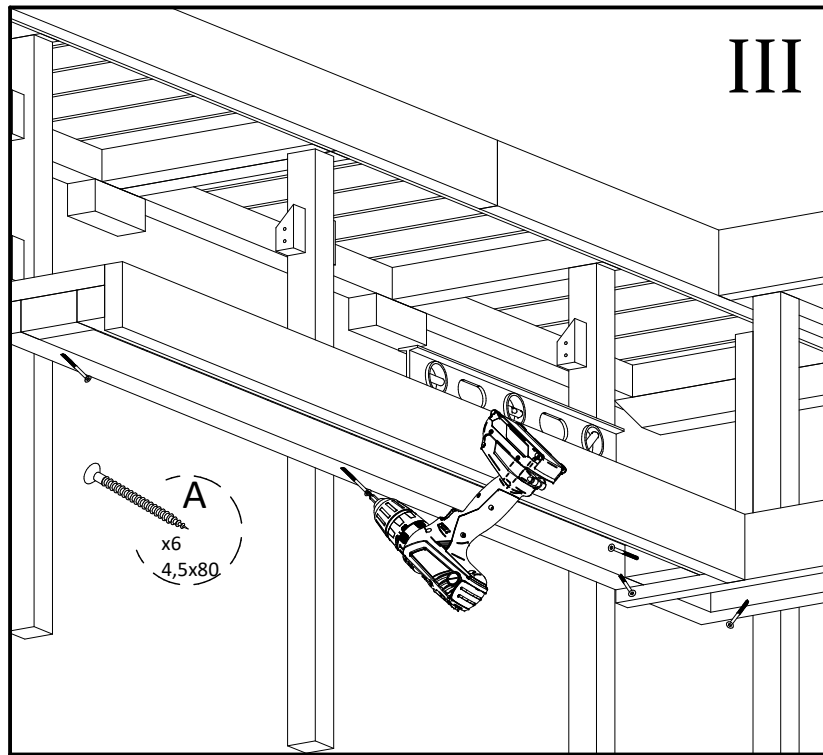
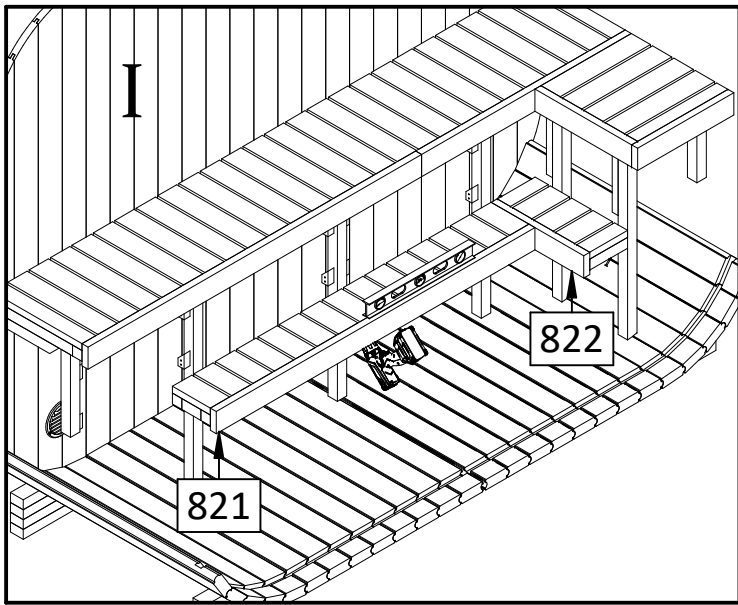

II

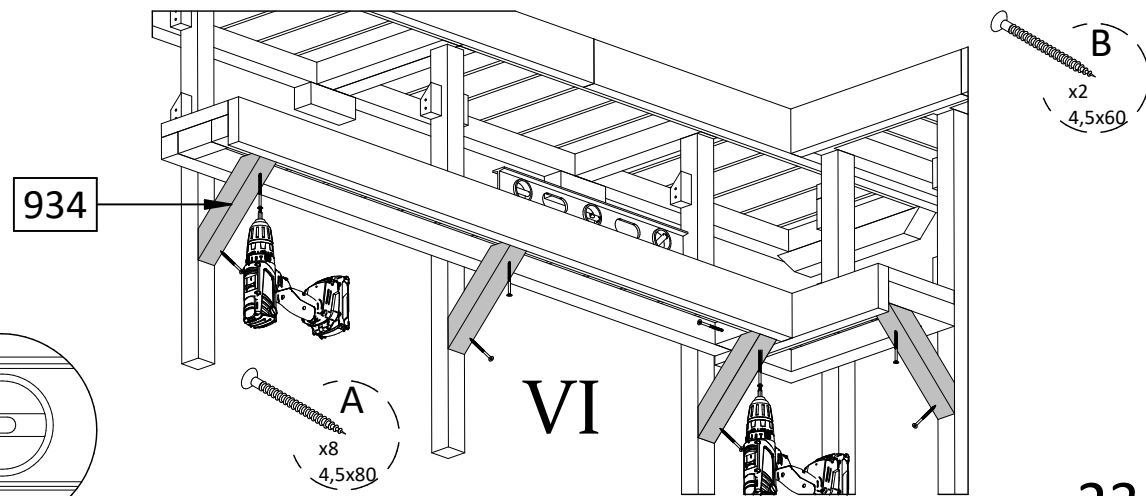
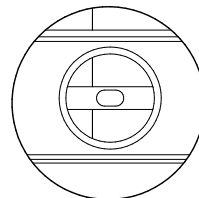
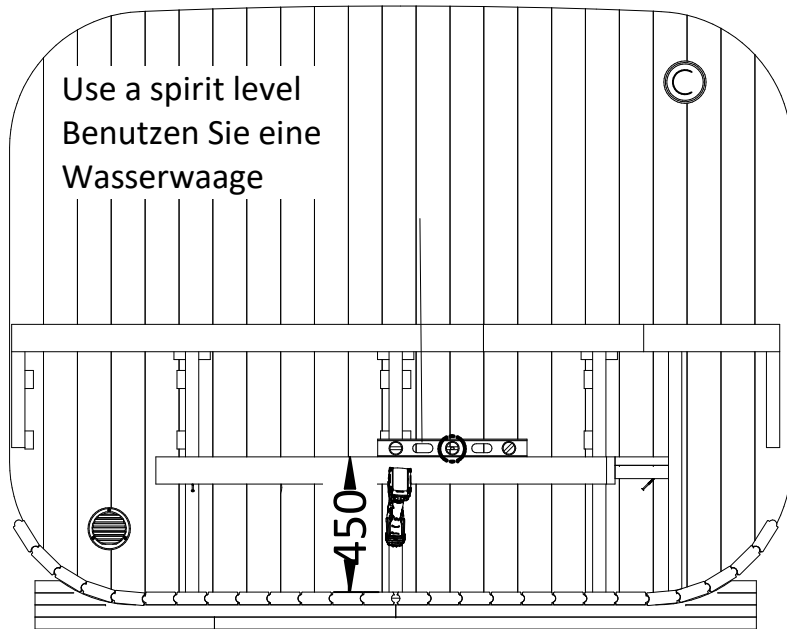

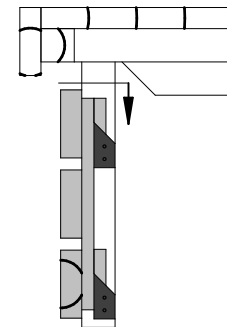
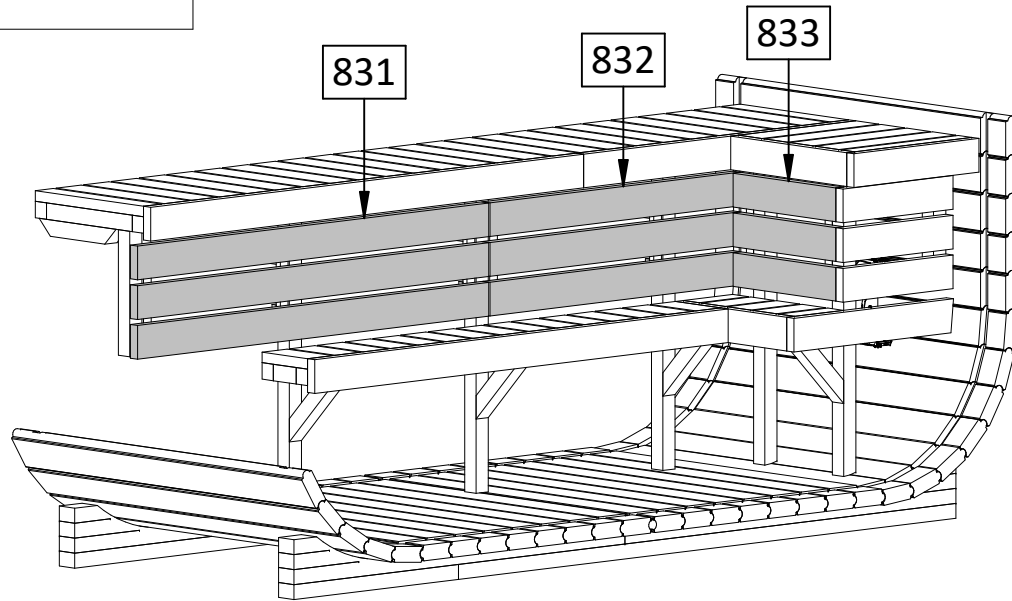
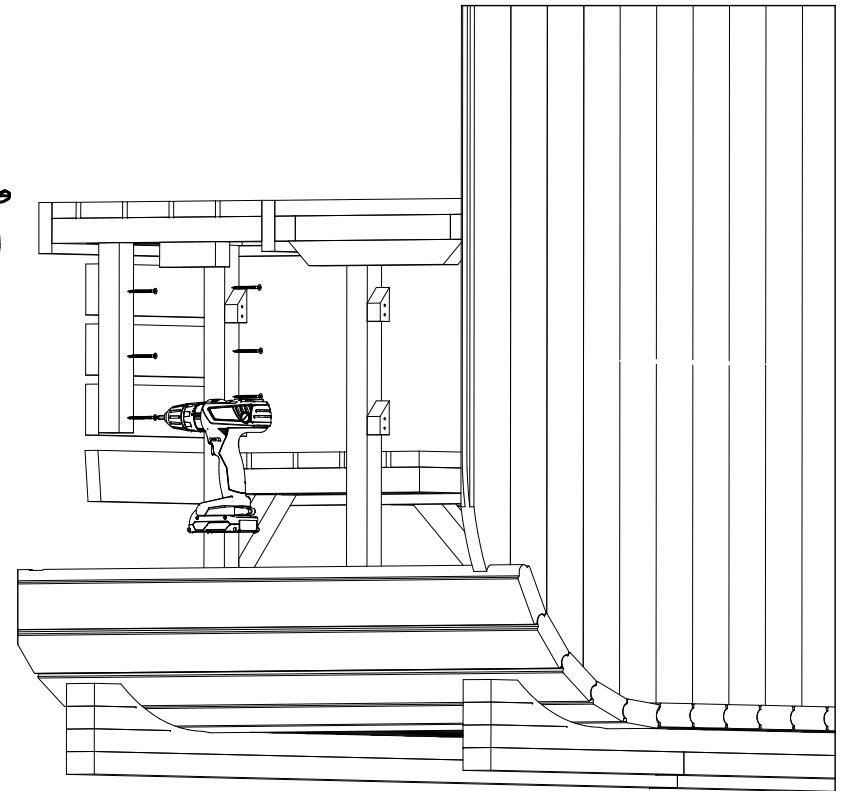
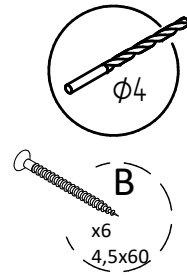
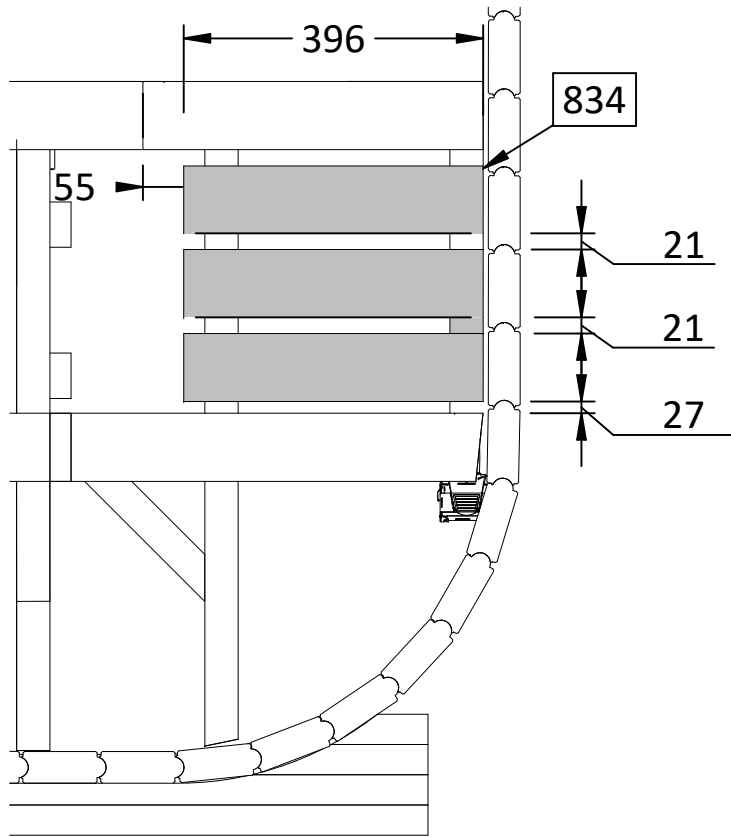

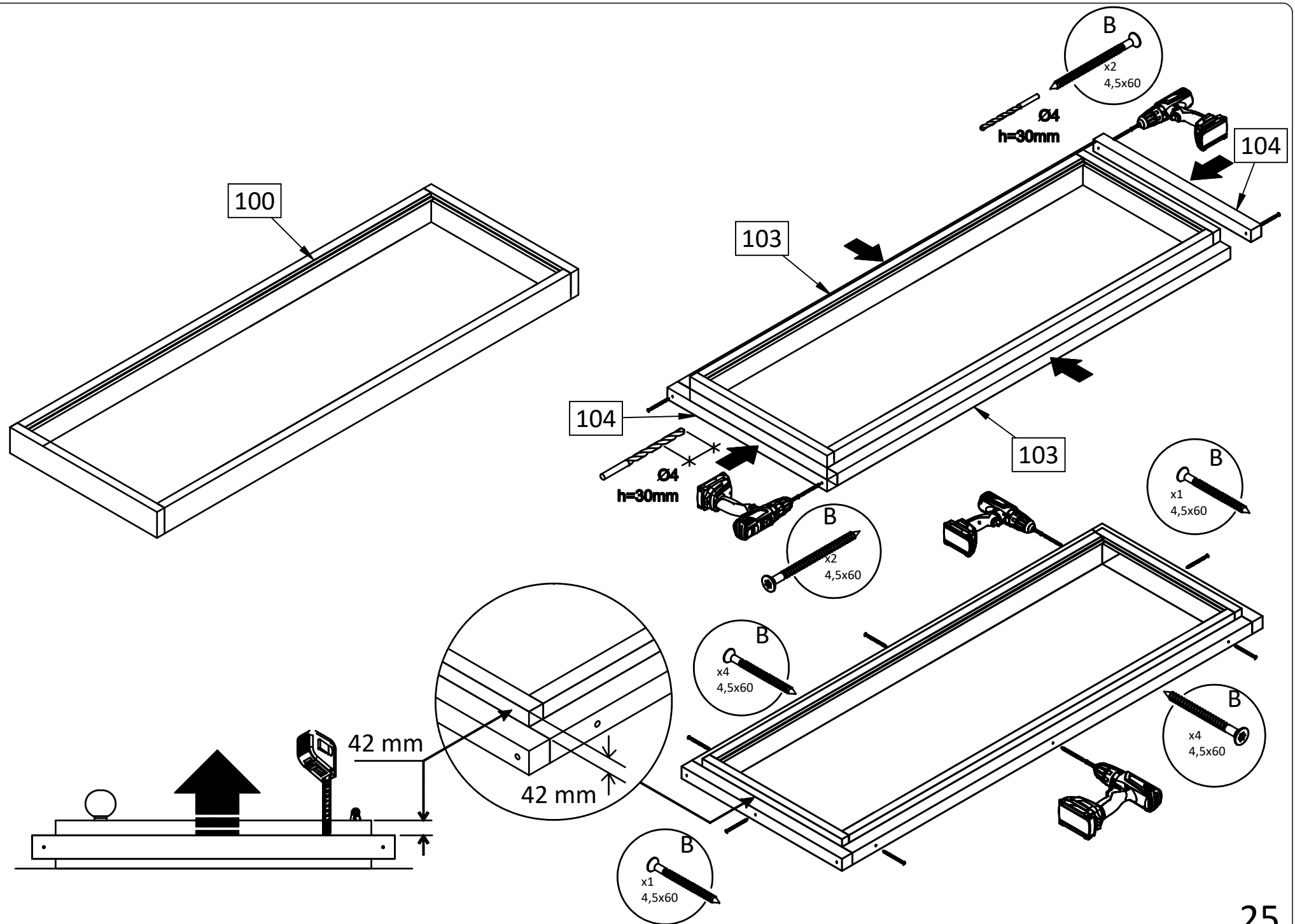

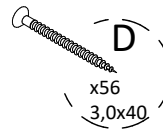
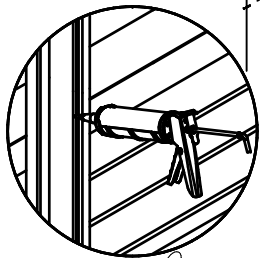
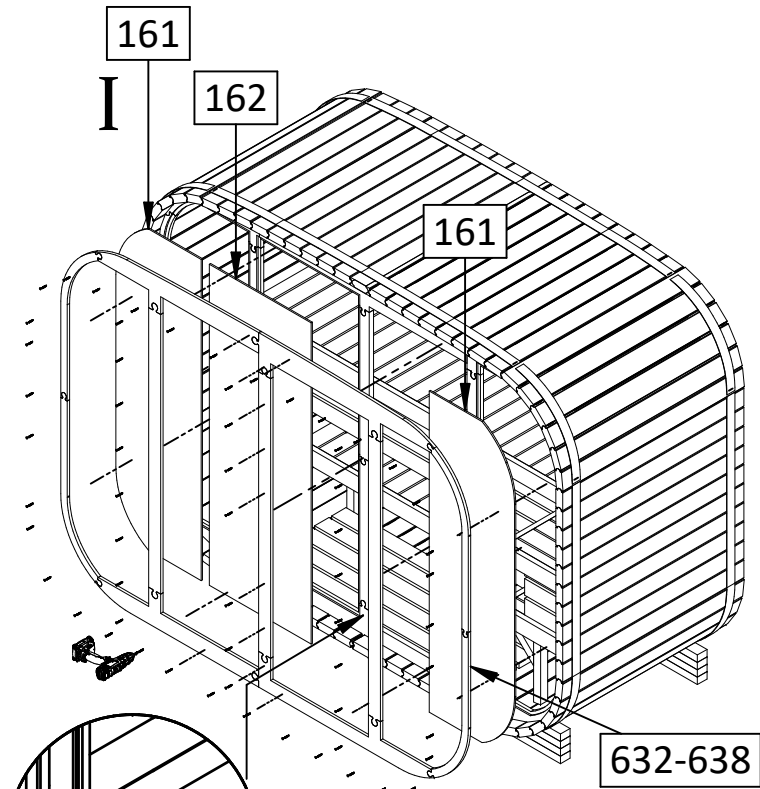

Before processing the screws.  
Pre-drill the holes  
with a  $\phi 3$ mm drill bit.

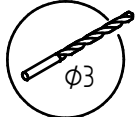

Bitte bohren Sie  
die  $\phi 3$ mm Löcher vor  
dem Schrauben vor

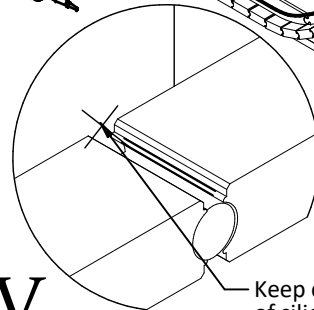
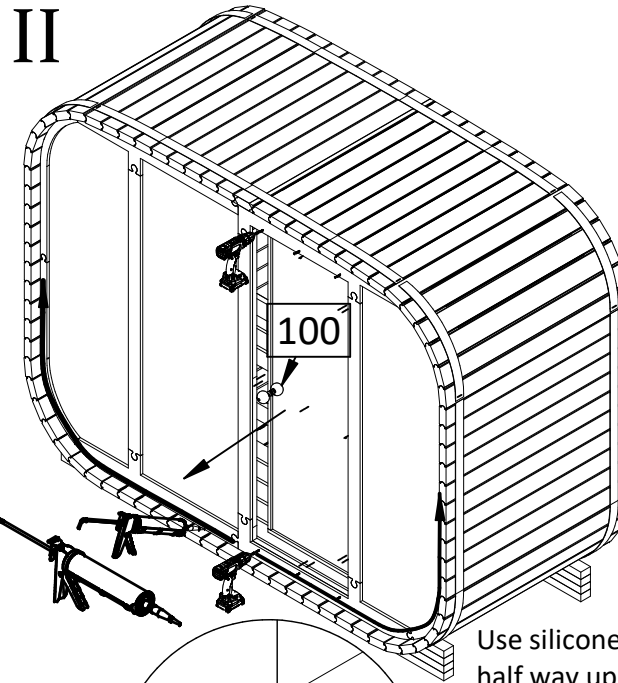
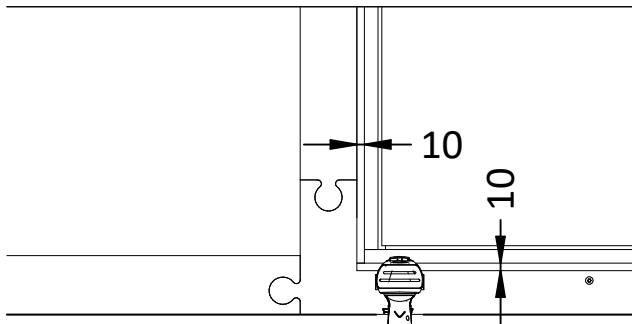

Use silicone  
half way up the wall

Benutzen Sie  
Silicon bis zur  
Hälfte  
der Wand

Keep clean  
of silicone

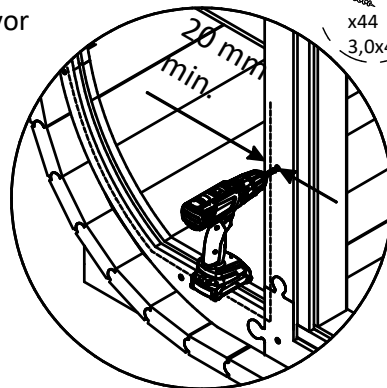
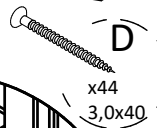

Use waterproof silicone

Verwenden Sie  
wasserfestes Silikon

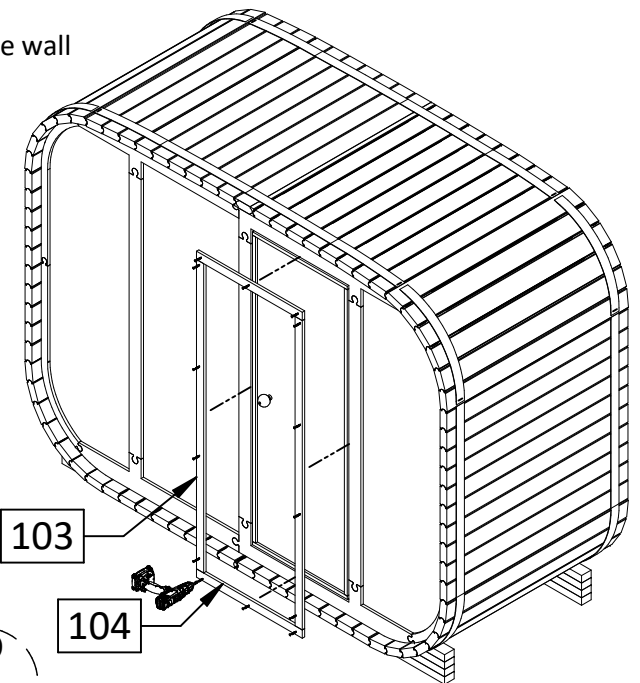
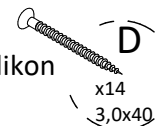

Attention! After installing the glass,  
tighten the straps completely.

Achtung! Nach Montage der Glas  
die Spanngurte vollständig spannen.

Before processing the screws.  
Pre-drill the holes  
with a  $\phi 3$ mm drill bit.

Bitte bohren Sie  
die  $\phi 3$ mm Löcher vor  
dem Schrauben vor

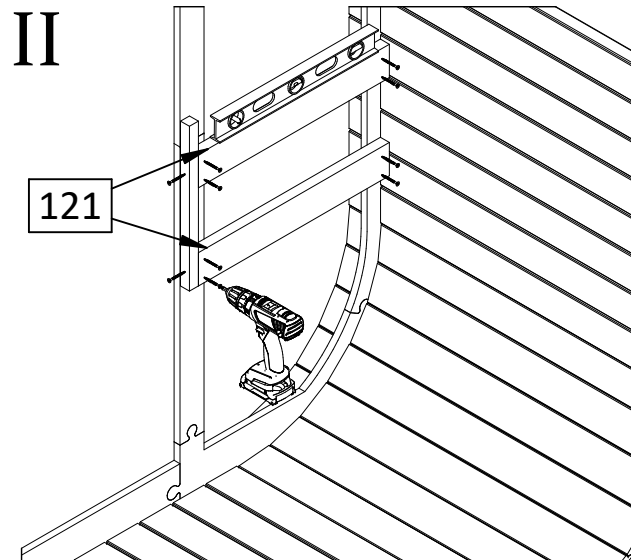
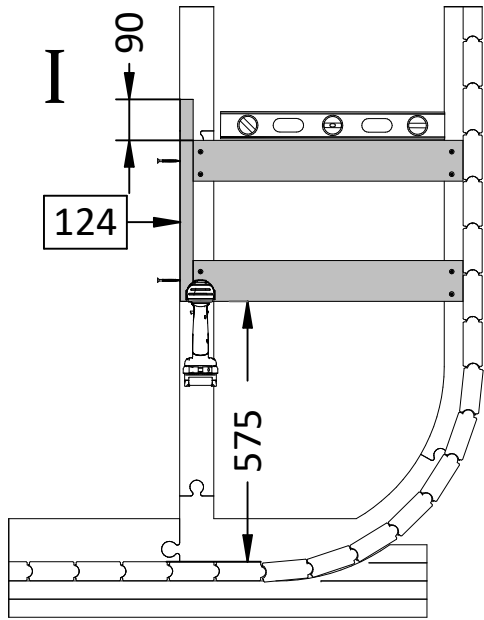

Use a spirit level  
Benutzen Sie eine  
Wasserwaage

Before processing the screws.  
Pre-drill the holes  
with a 4 mm drill bit.

Bitte bohren Sie  
die  $\Phi 4$ mm Löcher vor  
dem Schrauben vor

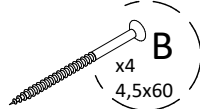
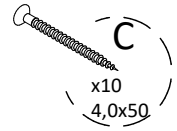
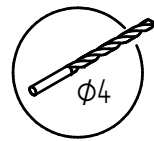

III

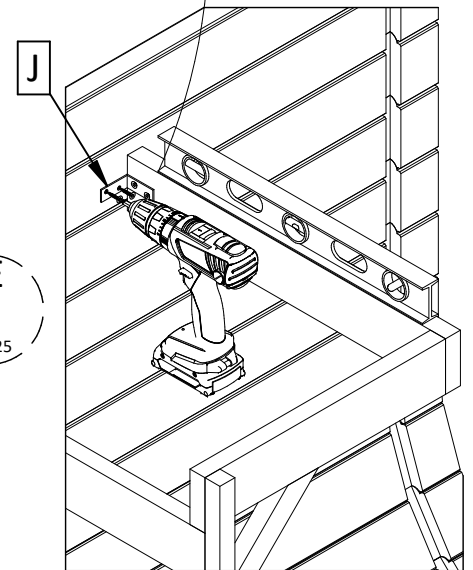
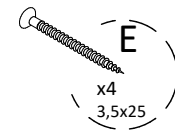
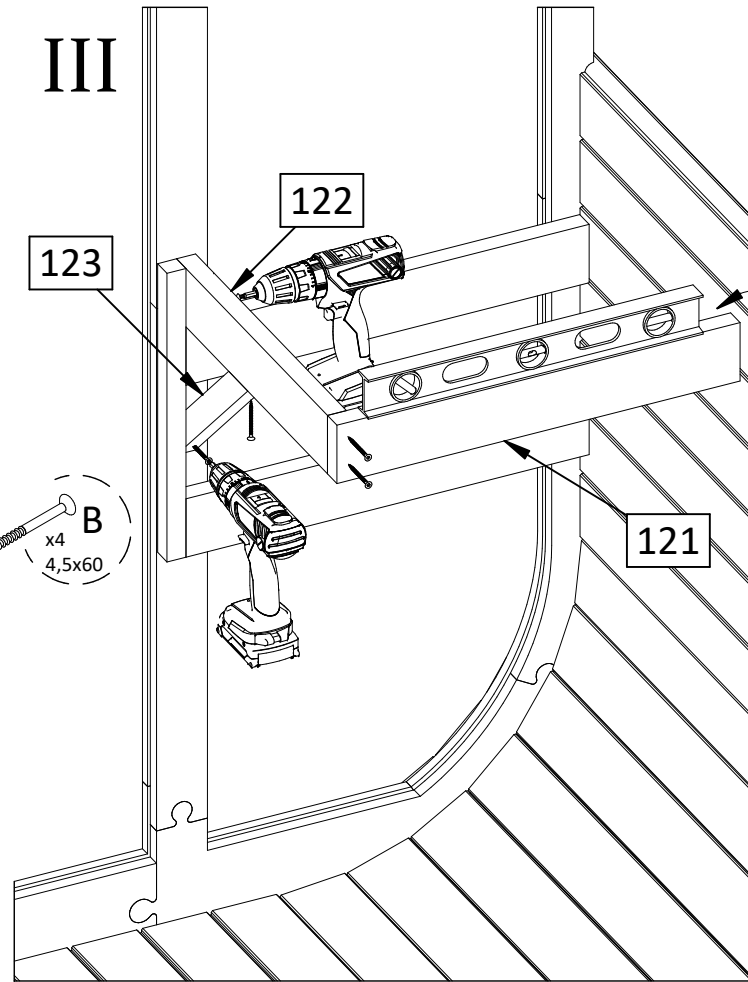

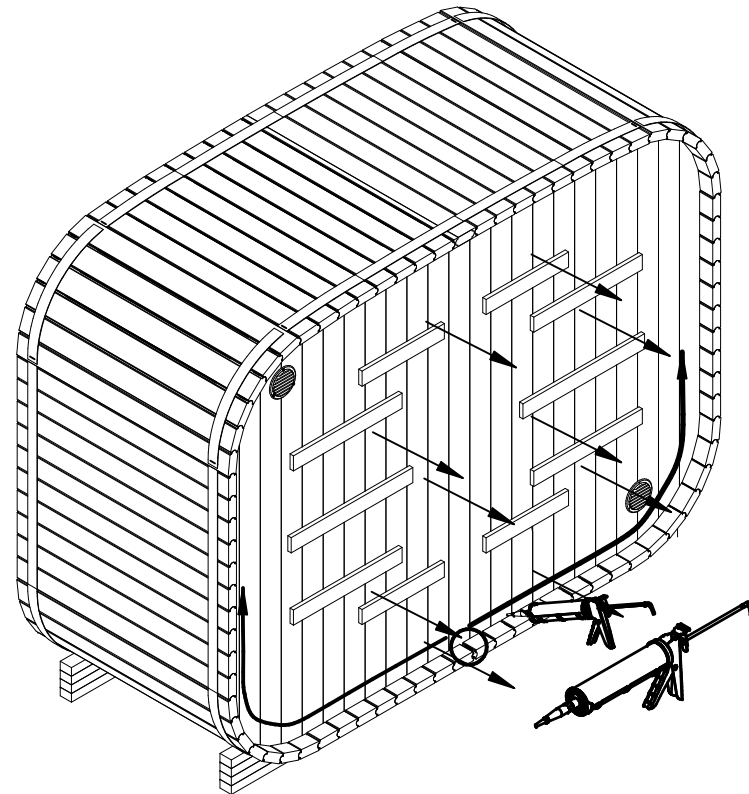

Use silicone half way up the wall

Benutzen Sie Silicon bis zur  
Hälfte der Wand

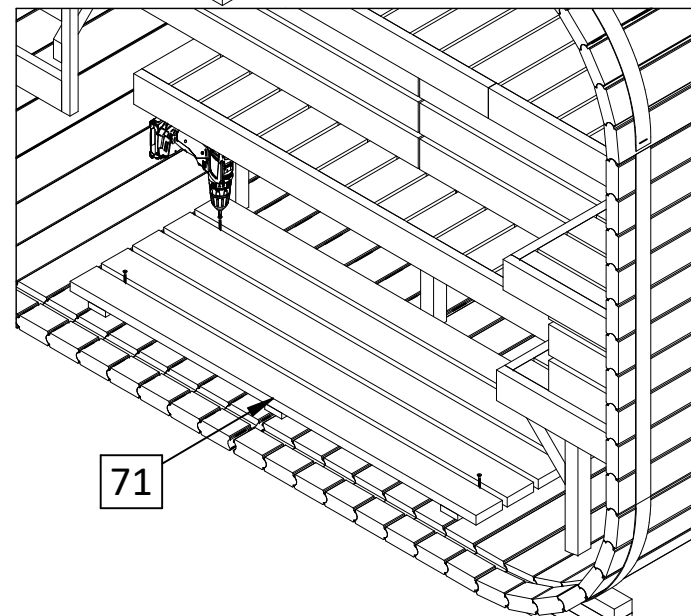
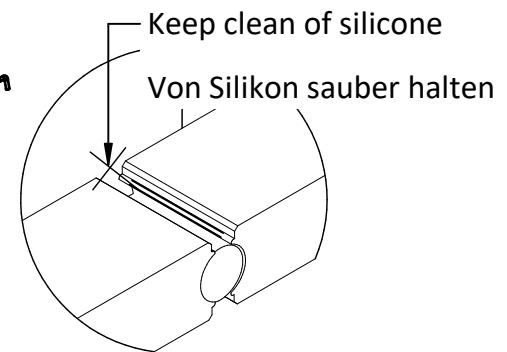

71



NB! Check also shingles installation manual inside the package.

# OPTIONAL

NB! Bitte bei Dachschindeln Montage beachten die Montageanleitung, welche in Dachschindeln Pakete liegt.

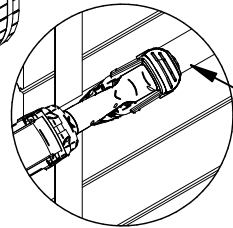
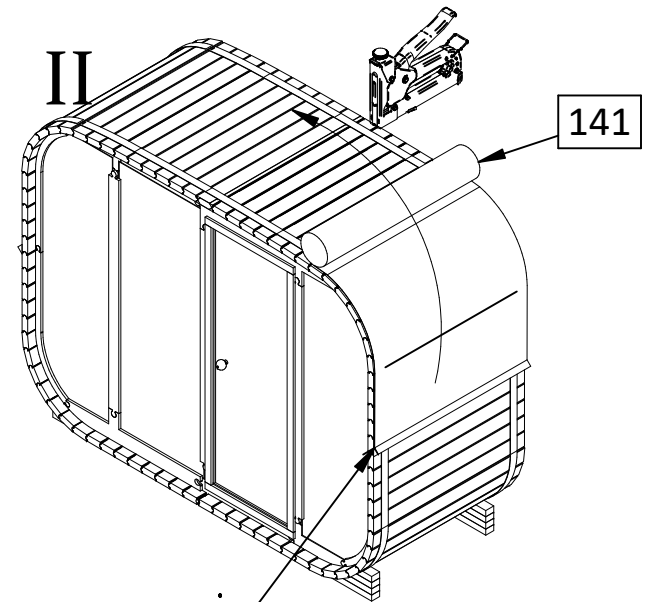
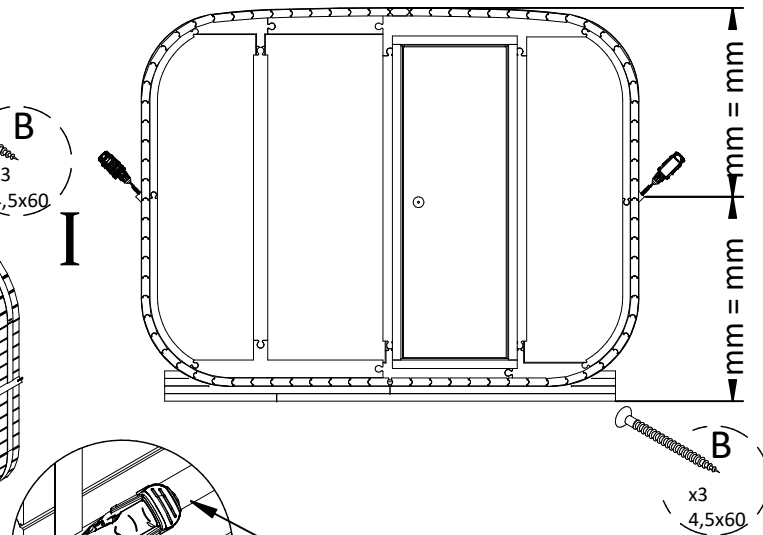
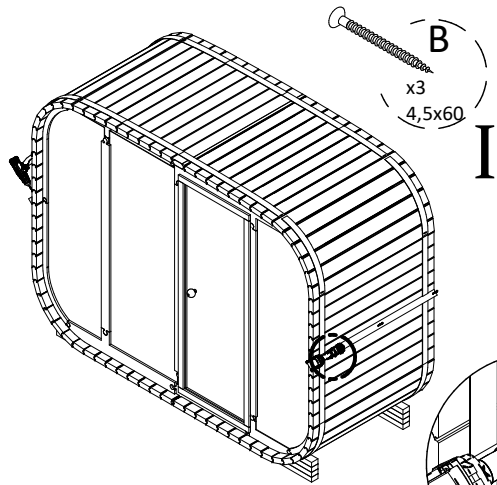

4

Please cut the clapping boards to size and use the other half on the other side.

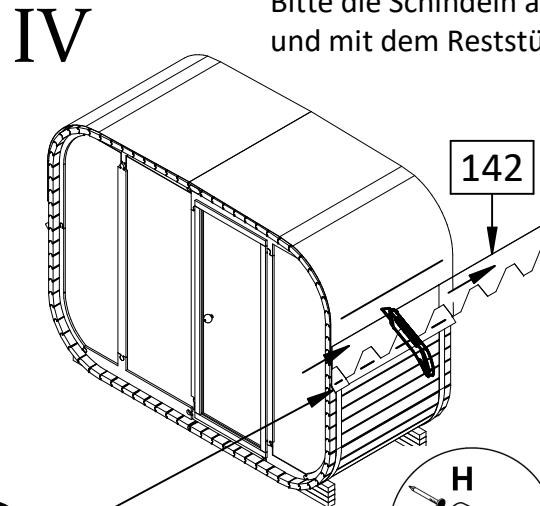
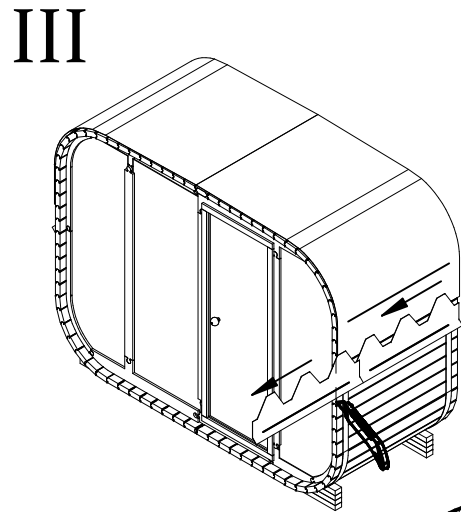
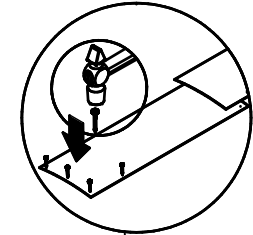
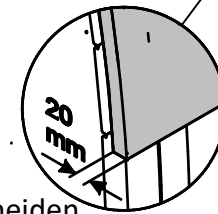

142

Bitte die Schindeln auf die richtige Länge schneiden und mit dem Reststück die neue Reihe anfangen.

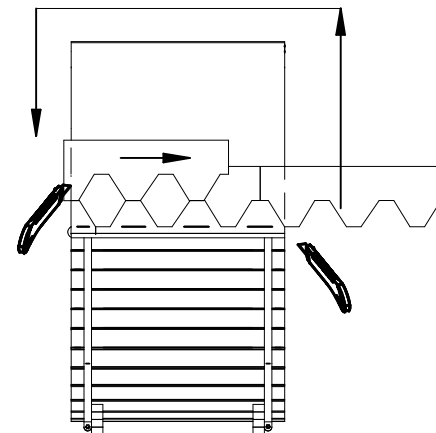

143

V

VI

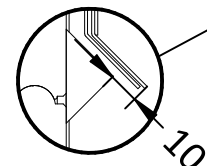

10

Attention! Leave a gap of 6 mm.

Achtung! Einen Zwischenraum von 6 mm lassen.

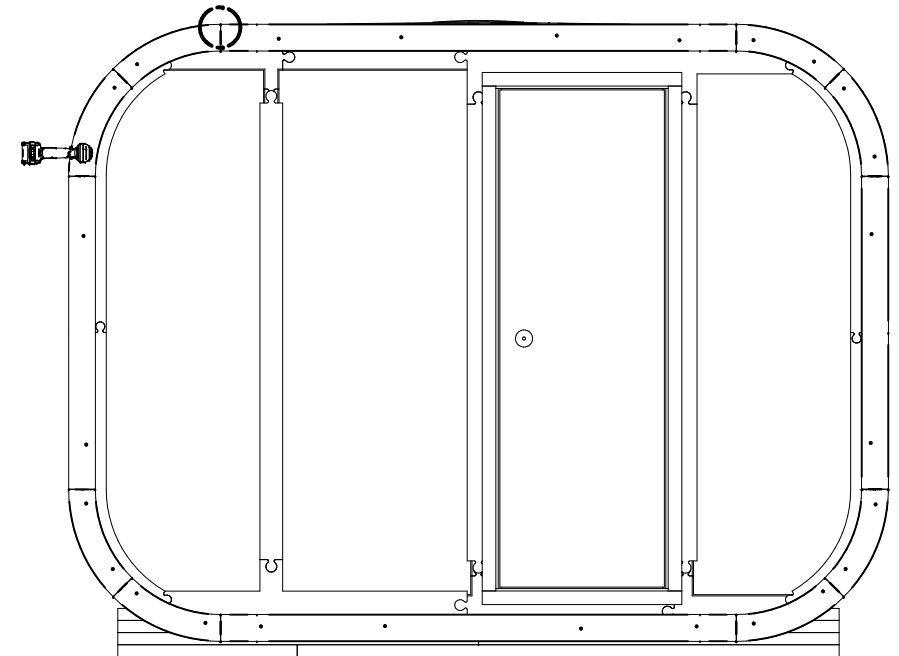
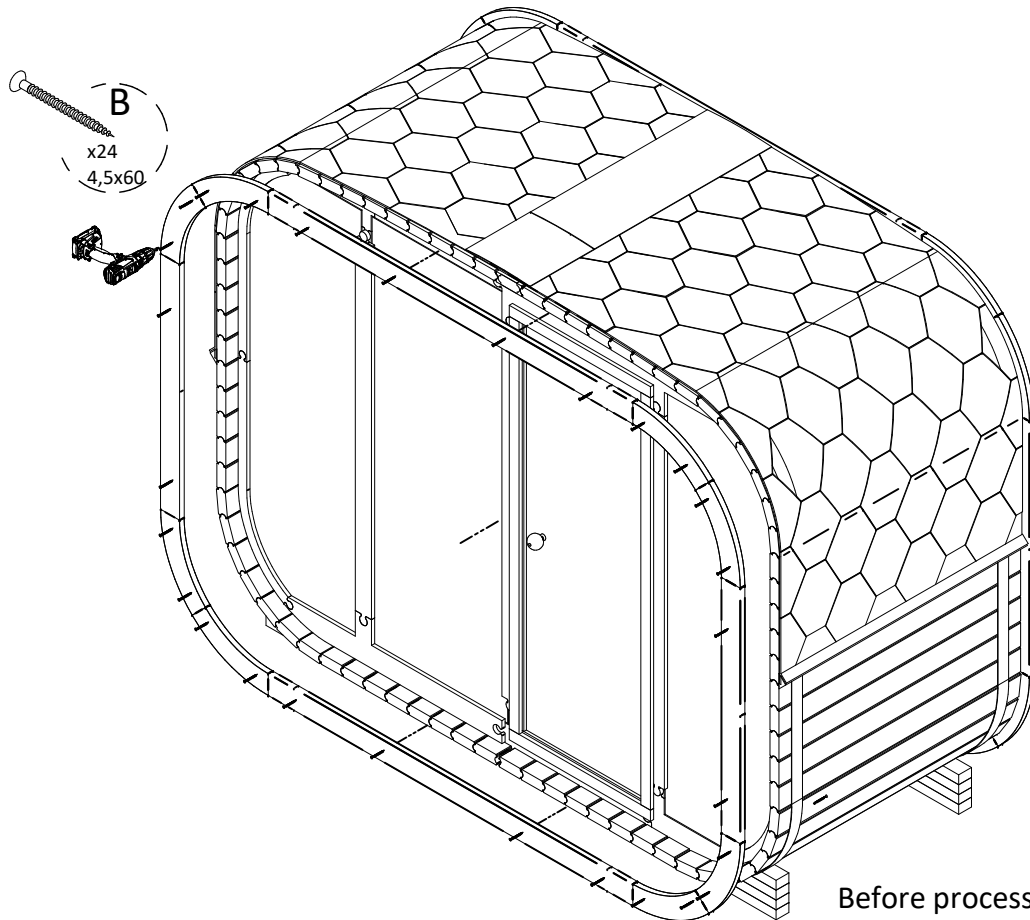
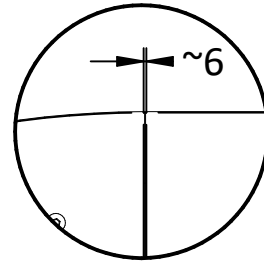

Before processing the screws.  
Pre-drill the holes  
with a  $\phi 4$ mm drill bit.

Bitte bohren Sie  
die  $\phi 4$ mm Löcher vor  
dem Schrauben vor

Falls nötig, schneiden Sie die Details in die passende Größe.  
If necessary, cut the details to the appropriate size